

# General Aluminum Gear Pumps and Motors

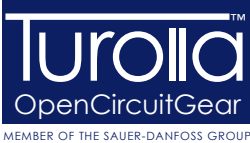

## Technical Information

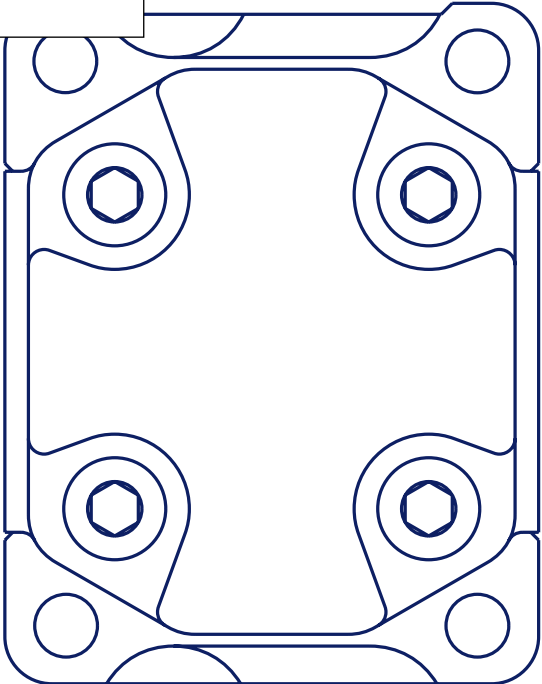
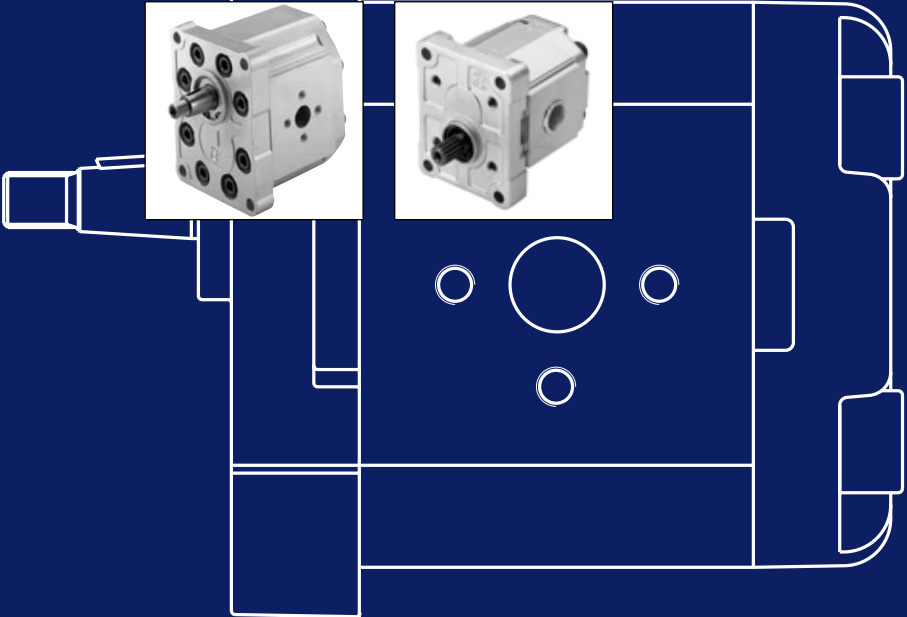
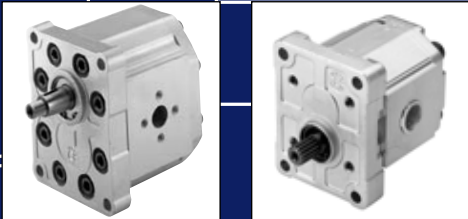
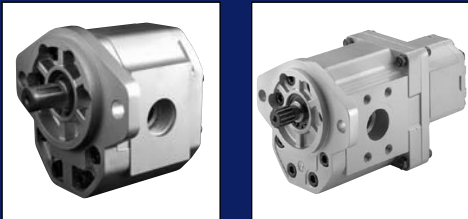
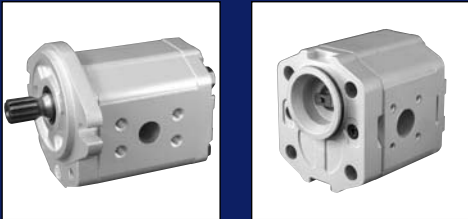
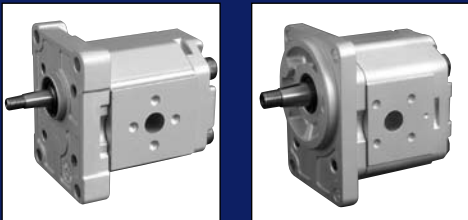

# General Aluminum Gear Pumps and Motors

## Technical Information

### General Information

#### Overview

This manual offers the TurollaOCG customer summarized technical information on all standard TurollaOCG gear pumps and motors and the standard available flanges, shafts, and ports. For detailed information on a particular product, please consult the specific technical manual for that product.

TurollaOCG gear pumps and motors are ideal for a wide range of applications for:

- **small vehicles**, such as aerial lifts, greens and fairway mowers and electric forklifts. These needs are ideally served by the aluminum pumps in the SKP1NN and SKP2NN ranges. These pumps feature integral valves and pressure balanced design for high efficiency, and extruded aluminum bodies for high strength.
- **medium and large off-highway vehicles**, like tractors, backhoe loaders, dumpers, and telescopic handlers, we offer the SNP2NN and SNP3NN.

Many combinations of the pumps mentioned are available as multiple units made to fit any need. TurollaOCG provides standard pumps for use in industrial applications, including power packs. Advantages include small package size, quiet operations, and low installed cost.

#### History of revisions

##### Table of revisions

Date	Page	Changed	Rev.
24, June 2010	-	First edition	A
24, Feb 2011	1,2,68	Covers to blue color, TurollaOCG brand name, Biofluids deleted.	B

#### Reference documents

##### Literature reference for gear products

Title	Type	Order number
Group 1 Gear Pumps	Technical Information	L1016399
Group 2 Gear Pumps	Technical Information	L1016341
Group 3 Gear Pumps	Technical Information	L1016456
Group 1, 2 and 3 Gear Motors	Technical Information	L1016082
Hydraulic Fluids and Lubricants	Technical Information	L1021414

© 2011 Turolla OpenCircuitGear™. All rights reserved.

TurollaOCG accepts no responsibility for possible errors in catalogs, brochures and other printed material. TurollaOCG reserves the right to alter its products without prior notice. This also applies to products already ordered provided that such alterations can be made without affecting agreed specifications. All trademarks in this material are properties of their respective owners. Sauer-Danfoss, Turolla, Turolla OpenCircuitGear, TurollaOCG, OpenCircuitGear, Fast Lane and PLUS+1 are trademarks of the Sauer-Danfoss Group.

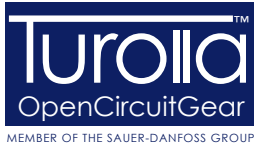

# General Aluminum Gear Pumps and Motors

## Technical Information

### Contents

<b>General Information</b>	Range.....	5
	Benefits .....	6
	Aluminum gear pumps and motors.....	6
	Pump displacements .....	7
	Motor displacements.....	8
<b>Model Code</b>	Model code for single pumps and motors.....	9
<b>Group 0.5</b>	Overview .....	12
	Design .....	12
	Features .....	12
	Technical data.....	12
	Dimensions • TFP0NN – 01FA.....	13
<b>Group 1</b>	Overview .....	14
	Design .....	14
	Features .....	14
	Technical data for pumps.....	15
	Technical data for motors .....	16
	Gear pump dimensions .....	17
	SNP1NN – 01BA and 01DA .....	17
	SKP1NN – 02BB and 02FA .....	18
	SNP1NN, SEP1NN – 03CA.....	19
	SKP1NN – 06GA and 06SA .....	20
	Gear motor dimensions .....	21
	SKM1NN – 01BA .....	21
	SKM1NN, SKU1NN – 02BB and 02FA .....	22
	SKM1NN – 06GA and 06SA.....	23
	Group 1 pump ports .....	24
	Group 1 motor ports .....	25
	Shaft and flange availability .....	26
<b>Group 2</b>	Overview .....	27
	Design .....	27
	Features .....	27
	Technical data for pumps.....	28
	Technical data for motors.....	29
	Gear pump dimensions .....	30
	SNP2NN – 01DA, 01FA and 01BA .....	30
	SNP2NN – 02DB and 02AA .....	31
	SNP2NN – 03CA.....	32
	SNP2NN – 04/05DB and 04/05AA .....	33
	SKP2NN – 06SB and SNP2NN – 06SA, 06GA .....	34
	SNP2NN – 06SA..BxBxYY../.....	35
	SNP2NN – 09BJ .....	36
	SNP2NN – A9BJ.....	37

# General Aluminum Gear Pumps and Motors

## Technical Information

### Contents

#### Group 2

Gear motor dimensions .....	38
SNM2NN – 01DA, 01FA and 01BA .....	38
SNM2NN – 02DB and 02AA .....	39
SNM2NN – 03CA.....	40
SNM2NN – 04/05DB and 04/05AA.....	41
SNM2NN – 06GA and 06SA .....	42
Group 2 pump ports .....	43
Group 2 motor ports .....	44
Shaft options.....	45
Shaft and flange availability .....	45
Shaft and flange availability and torque capability.....	45

#### Group 3

Overview .....	46
Design .....	46
Features .....	46
Technical data for pumps .....	47
Technical data for motors.....	48
Gear pump dimensions.....	49
SNP3NN – 01FA, 01DA, 01BA and SEP3NN – 01BA .....	49
SNP3NN – 02FA, 02DA and 02BA .....	50
SNP3NN – 03FB and 03BB.....	51
SNP3NN – 06DD and 06AA.....	52
SNP3NN, SEP3NN – 07SA, 07GA .....	53
Gear motor dimensions .....	54
SNM3NN – 01FA, 01DA and 01BA .....	54
SNM3NN – 02FA, 02DA and 02BA.....	55
SNM3NN – 03FB and 03BB .....	56
SNM3NN – 06DD and 06AA .....	57
SNM3NN – 07BC, 07SA and 07GA .....	58
Group 3 pump ports .....	59
Group 3 motor ports .....	60
Shaft and flange availability .....	61
Shaft and flange availability and torque capability.....	61

#### Multi-Stage Pumps

Overview .....	62
Multi-stage pump model code.....	63
Multi-stage pumps with European standard front flange (01).....	66

## General Aluminum Gear Pumps and Motors Technical Information General Information

### Range

**TuroliaOCG** offers a wide range of gear products to meet most application needs. The catalogue highlights the range of aluminum and cast iron gear pumps and motors available from TuroliaOCG. Detailed specifications are included for all products. Many other configurations are available that are not included in this catalogue. For further information, please contact your TuroliaOCG representative.

### Aluminum gear pumps and motors

There are five families of aluminum pumps currently available: **Group 0.5, 1, 2, 3** and **4**, some can be combined to make multiple pumps. And there are three families of aluminum motors: **Group 1, 2** and **3**.

Pumps and motors with extruded aluminum housing provide the necessary strength construction while providing a very high power-to-weight ratio and increased heat dissipation. At production test, the gear teeth cut their own track in the aluminum body for maximum radial gear tip sealing and high volumetric efficiency.

### *Aluminum gear pumps and motors*



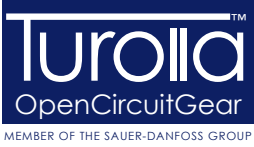

# General Aluminum Gear Pumps and Motors

## Technical Information

### General Information

#### Benefits

**TurollaOCG** offers gear pumps and motors throughout a wide range of displacements. Each has its own unique benefits that, briefly, include in part or total:

- Large displacement range (from 0.25 to 194.3 cm<sup>3</sup>/rev [0.015 to 11.86 in<sup>3</sup>/rev])
- High performance and cost effective
- Efficient pressure-balanced design
- Proven reliability and performance
- Optimum product configurations
- Full range of auxiliary features
- Compact, lightweight
- Modular product design
- Quiet operation
- Worldwide manufacture, sales and service

TurollaOCG pumps and motors pressure-balanced design provides high efficiency throughout a given range of displacements.

One-piece gear/shaft construction provides both high strength and an accurate profile. Each integral gear/shaft is constructed of bearing-quality hardened-steel that is machined to precise tolerances for minimum leakage. This one-piece design also eliminates the potential problems of stress-fatigue often associated with two-piece designs.

All TurollaOCG gear pumps use hydrodynamic journal bearings that have an oil film maintained between the gear/shaft and bearing surfaces at all times. If this oil film is sufficiently sustained through proper system maintenance and operating within recommended limits a long pump life can be expected.

**Pump displacements**

Quick reference chart for pump displacements vs. rated pressure

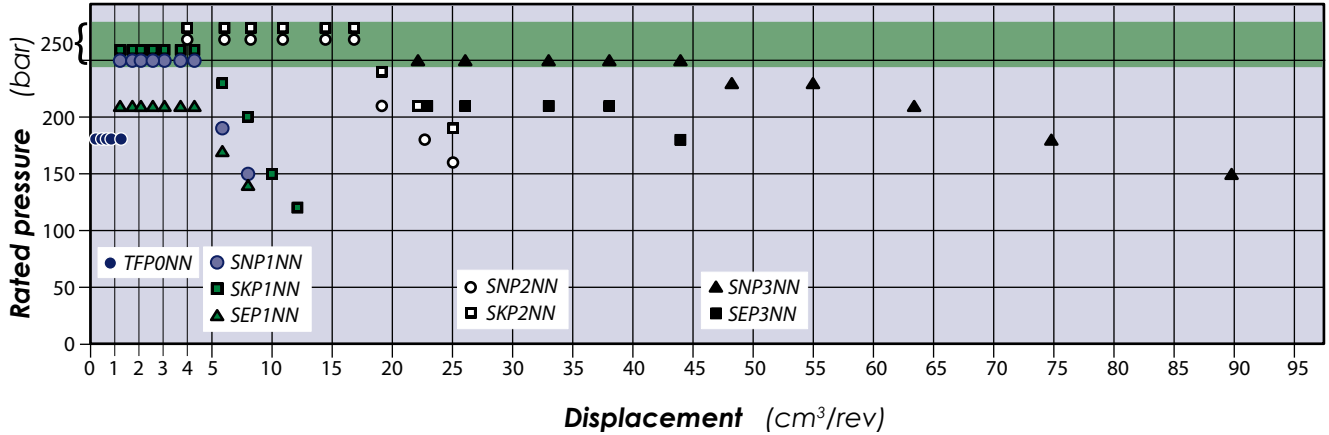

**Motor displacements**

Quick reference chart for motor displacements vs. rated pressure

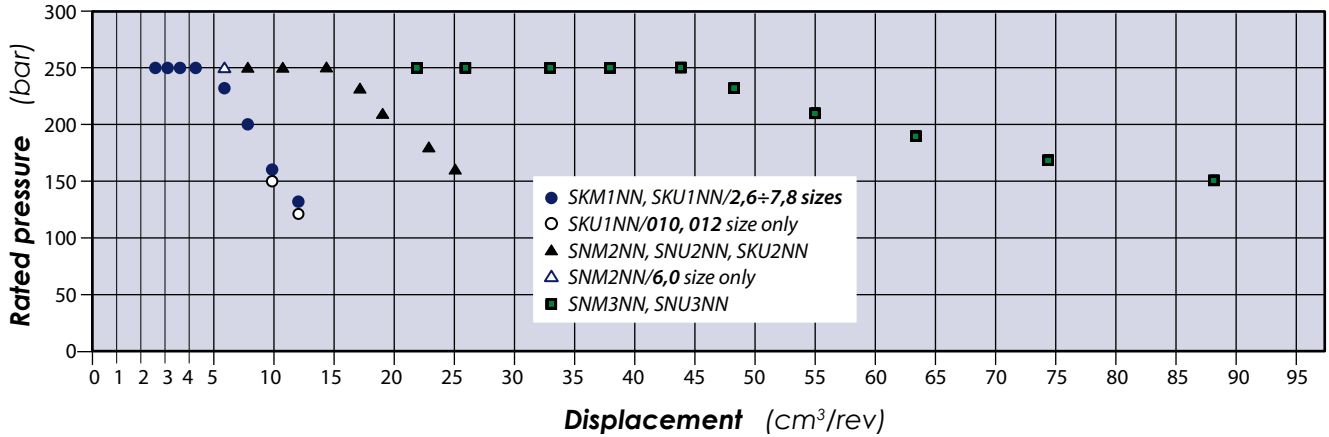

# General Aluminum Gear Pumps and Motors

## Technical Information

### Product Coding

#### Model code for single pumps and motors

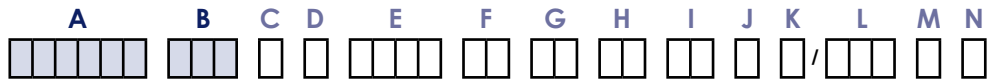

#### A Type

<b>Pumps</b>	<b>TFP0NN, SNP1NN, SNP2NN, SNP3NN</b>	Standard gear pumps
	<b>SKP1NN, SKP2NN</b>	High torque gear pumps
	<b>SEP1NN, SEP2NN, SEP3NN</b>	Medium pressure gear pumps
	<b>SNP11N, SNP21N</b>	Gear pumps with internal drain relief valve

<b>Motors</b>	<b>SKM1NN, SNM2NN, SNM3NN</b>	Standard bi-directional gear motors
	<b>SKU1NN, SKU2NN</b>	High torque uni-directional gear motors
	<b>SNU1NN, SNU2NN, SNU3NN</b>	Uni-directional gear motors

#### B Displacement

Group 0.5 pump	Frame size	Displacement cm <sup>3</sup> /rev [in <sup>3</sup> /rev]
	<b>,25</b>	0.25 [0.015]
	<b>,45</b>	0.45 [0.027]
	<b>,57</b>	0.57 [0.034]
	<b>,76</b>	0.76 [0.045]
	<b>1,3</b>	1.30 [0.079]

#### Legend:

- Standard
- Optional
- Not Available

#### B Displacement (cont.)

Group 1 pumps	Frame size	Displacement cm <sup>3</sup> /rev [in <sup>3</sup> /rev]	SNP1NN	SEP1NN	SKP1NN	SNP11N
	<b>1,2</b>	1.18 [0.072]	●	●	●	●
	<b>1,7</b>	1.57 [0.096]	●	●	●	●
	<b>2,2</b>	2.09 [0.128]	●	●	●	●
	<b>2,6</b>	2.62 [0.160]	●	●	●	●
	<b>3,2</b>	3.14 [0.192]	●	●	●	●
	<b>3,8</b>	3.66 [0.223]	●	●	●	●
	<b>4,3</b>	4.19 [0.256]	●	●	●	●
	<b>6,0</b>	5.89 [0.359]	●	●	●	●
	<b>7,8</b>	7.59 [0.463]	●	●	●	●
	<b>010</b>	9.94 [0.607]	-	-	●	-
	<b>012</b>	12.0 [0.732]	-	-	●	-

Group 2 pumps	Frame size	Displacement cm <sup>3</sup> /rev [in <sup>3</sup> /rev]	SNP2NN	SEP2NN	SKP2NN	SNP21N
	<b>4,0</b>	3.9 [0.24]	●	●	●	●
	<b>6,0</b>	6.0 [0.37]	●	●	●	●
	<b>8,0</b>	8.4 [0.51]	●	●	●	●
	<b>011</b>	10.8 [0.66]	●	●	●	●
	<b>014</b>	14.4 [0.88]	●	●	●	●
	<b>017</b>	16.8 [1.02]	●	●	●	●
	<b>019</b>	19.2 [1.17]	●	●	●	●
	<b>022</b>	22.8 [1.39]	●	●	●	●
	<b>025</b>	25.2 [1.54]	●	●	●	●

Group 3 pumps	Frame size	Displacement cm <sup>3</sup> /rev [in <sup>3</sup> /rev]	SNP3NN	SEP3NN
	<b>022</b>	22.1 [1.35]	●	●
	<b>026</b>	26.2 [1.60]	●	●
	<b>033</b>	33.1 [2.02]	●	●
	<b>038</b>	37.9 [2.32]	●	●
	<b>044</b>	44.1 [2.69]	●	●
	<b>048</b>	48.3 [2.93]	●	-
	<b>055</b>	55.1 [3.36]	●	-
	<b>063</b>	63.4 [3.87]	●	-
	<b>075</b>	74.4 [4.54]	●	-
<b>090</b>	88.2 [5.38]	●	-	

Group 1 motors	Frame size	Displacement cm <sup>3</sup> /rev [in <sup>3</sup> /rev]	SKM1NN	SKU1NN	SNU1NN
	<b>2,6</b>	2.62 [0.160]	●	●	●
	<b>3,2</b>	3.14 [0.192]	●	●	●
	<b>3,8</b>	3.66 [0.223]	●	●	●
	<b>4,3</b>	4.19 [0.256]	●	●	●
	<b>6,0</b>	5.89 [0.359]	●	●	●
	<b>7,8</b>	7.59 [0.463]	●	●	●
	<b>010</b>	9.94 [0.607]	●	●	●
<b>012</b>	12.0 [0.732]	●	●	●	

Group 2 motors	Frame size	Displacement cm <sup>3</sup> /rev [in <sup>3</sup> /rev]	SNM2NN	SKU2NN	SNU2NN
	<b>6,0</b>	6.0 [0.37]	●	-	-
	<b>8,0</b>	8.4 [0.51]	●	●	●
	<b>011</b>	10.8 [0.66]	●	●	●
	<b>014</b>	14.4 [0.88]	●	●	●
	<b>017</b>	16.8 [1.02]	●	●	●
	<b>019</b>	19.2 [1.17]	●	●	●
	<b>022</b>	22.8 [1.39]	●	●	●
	<b>025</b>	25.2 [1.54]	●	●	●

Group 3 motors	Frame size	Displacement cm <sup>3</sup> /rev [in <sup>3</sup> /rev]	SNM3NN	SNU3NN
	<b>022</b>	22.1 [1.35]	●	●
	<b>026</b>	26.2 [1.60]	●	●
	<b>033</b>	33.1 [2.02]	●	●
	<b>038</b>	37.9 [2.32]	●	●
	<b>044</b>	44.1 [2.69]	●	●
	<b>048</b>	48.3 [2.93]	●	●
	<b>055</b>	55.1 [3.36]	●	●
	<b>063</b>	63.4 [3.87]	●	●
	<b>075</b>	74.4 [4.54]	●	●
<b>090</b>	88.2 [5.38]	●	●	



### Model code for single pumps and motors (continued)

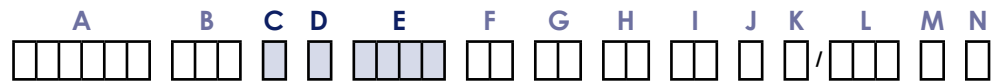

#### C Direction of rotation

<b>R</b>	Right hand (clockwise)
<b>L</b>	Left hand (counterclockwise)
<b>B</b>	For reversible motors

#### D Version \*

<b>N</b>	Standard version of project
----------	-----------------------------

\* value representing a change to the initial project

#### E Mounting flange and gear shaft

Code	Mounting Flange Type	Gear Shaft Type	Preferred Ports for Configuration	TFP0NN	SNP1NN	SKP1NN	SEP1NN	SNP1IN	SKM1NN	SKU1NN	SNU1NN	SNP2NN	SKP2NN	SEP2NN	SNP2IN	SNM2NN	SNU2NN	SNP3NN	SEP3NN	SNM3NN	SNU3NN
01FA	European 2-bolt	Parallel	Metrical threaded	●	-	-	-	-	-	-	-	-	-	-	-	-	-	-	-	-	-
	European 4-bolt	Parallel	European flanged	-	-	-	-	-	-	-	-	●	-	-	●	●	●	●	●	●	●
01BA	European 4-bolt	Tapered 1:8	European flanged	-	●	●	-	●	●	-	●	●	-	●	●	●	●	●	●	●	●
	European 4-bolt	DIN Splined 9T	European flanged	-	-	-	-	-	-	-	-	●	-	-	●	●	●	-	-	-	-
01DA	European 4-bolt	DIN Splined 13T	European flanged	-	-	-	-	-	-	-	-	-	-	-	-	-	-	●	-	●	●
	European 4-bolt	Splined 15T	European flanged	-	●	-	-	●	-	-	-	●	-	-	●	●	●	●	-	●	●
	European 4-bolt	DIN Splined 9T	European flanged	-	-	-	-	-	-	-	-	●	-	-	●	●	●	-	-	-	-
02AA	German 4-bolt PTO	Tapered 1:5	German flanged	-	-	-	-	-	-	-	-	●	-	-	●	●	●	-	-	-	-
02BA	European 4-bolt	Tapered 1:8	European flanged	-	-	-	-	-	-	-	-	-	-	-	-	-	-	●	-	-	-
02BB	European 4-bolt	Tapered 1:8	European flanged	-	-	●	-	-	●	-	-	-	-	-	-	-	-	-	-	-	-
02DA	European 4-bolt	DIN splined 13T	European flanged	-	-	-	-	-	-	-	-	-	-	-	-	-	-	●	-	-	-
02DB	German 4-bolt PTO	DIN splined 9T	German flanged	-	-	-	-	-	-	-	-	●	-	-	●	●	●	-	-	-	-
02FA	European 4-bolt	Parallel	European flanged	-	-	●	-	-	●	●	-	-	-	-	-	-	-	●	-	-	-
03BB	European 4-bolt	Tapered 1:8	European flanged	-	-	-	-	-	-	-	-	-	-	-	-	-	-	●	-	●	●
03CA	German 2-bolt PTO	TuroliaOCG Tang	Metrical threaded	-	●	-	●	●	-	-	-	-	-	-	-	-	-	-	-	-	-
03CA	4-bolt for multiples	TuroliaOCG Tang	German flanged	-	-	-	-	-	-	-	-	●	-	-	●	●	●	-	-	-	-
03FB	European 4-bolt	Parallel	European flanged	-	-	-	-	-	-	-	-	-	-	-	-	-	-	●	-	●	-
04AA	German 2-bolt PTO	Tapered 1:5	German flanged	-	-	-	-	-	-	-	-	●	-	-	●	●	●	-	-	-	-
04DB	German 2-bolt PTO	DIN splined	German flanged	-	-	-	-	-	-	-	-	●	-	-	●	●	●	-	-	-	-
05AA	German 2-bolt PTO	Tapered 1:5	German flanged	-	-	-	-	-	-	-	-	●	-	-	●	●	●	-	-	-	-
05DB	German 2-bolt PTO	DIN splined	German flanged	-	-	-	-	-	-	-	-	●	-	-	●	●	●	-	-	-	-
06AA	German 4-bolt PTO	Tapered 1:5	German flanged	-	-	-	-	-	-	-	-	-	-	-	-	-	-	●	-	●	●
06GA	SAE A-A	Parallel	SAE O-ring boss	-	-	●	-	-	●	●	-	-	-	-	-	-	-	-	-	-	-
	SAE A	Parallel	SAE O-ring boss	-	-	-	-	-	-	-	-	●	-	-	●	●	●	-	-	-	-
06SA	SAE A-A	SAE splined 9T	SAE O-ring boss	-	-	●	-	-	●	-	-	-	-	-	-	-	-	-	-	-	-
	SAE A	SAE splined 9T	SAE O-ring boss	-	-	-	-	-	-	-	-	●	-	-	●	●	●	-	-	-	-
06SB	SAE A-A	SAE splined 11T	SAE O-ring boss	-	-	-	-	-	-	-	-	●	-	-	-	-	-	-	-	-	-
06DD	German 4-bolt PTO	DIN splined 15T	German flanged	-	-	-	-	-	-	-	-	-	-	-	-	-	-	●	-	-	-
07BC	SAE B flange	Tapered 1:8	Vertical 4-bolt SAE flanged	-	-	-	-	-	-	-	-	-	-	-	-	-	-	-	-	●	●
07GA	SAE B flange	Parallel	Vertical 4-bolt SAE flanged	-	-	-	-	-	-	-	-	-	-	-	-	-	-	●	-	●	●
07SA	SAE B flange	SAE splined 13T	Vertical 4-bolt SAE flanged	-	-	-	-	-	-	-	-	-	-	-	-	-	-	●	●	●	●
09BJ	Perkins 4.236 timing case	Tapered 1:8	European flanged	-	-	-	-	-	-	-	-	●	-	-	-	-	-	-	-	-	-
09BJ	Perkins 900 series	Tapered 1:8	European flanged	-	-	-	-	-	-	-	-	●	-	-	-	-	-	-	-	-	-

For further details of design and size for:

- Group 1, see pages 24–25,
- Group 2, see pages 43–44
- Group 3, see pages 59–60.

Legend:	
●	Standard
○	Optional
-	Not Available

# General Aluminum Gear Pumps and Motors

## Technical Information

### Product Coding

Model code for single pumps and motors (continued)

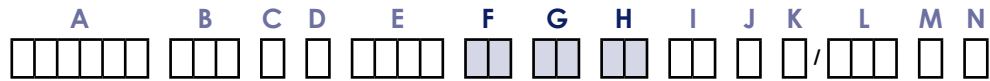

#### F Rear cover

Pumps		
Gr. 0.5	P1	Standard cover for pump
	R1	Standard cover for reversible pump
Group 1	P1	Standard cover for pump
	03	Cover for 03 flange
	I1	Cover for pump with relief valve
Group 2	I3	Cover for 03 flange with relief valve
	P1	Standard cover for pump
	P3	Cover for 03 flange only
	C1	Front BSP ports: Inlet 3/4 GAS; Outlet 1/2 GAS
	C6	Front SAE threaded ports: Inlet 1 1/16-12UN-2B; Outlet 7/8-14UNF-2B
	E1	Cover per RV external drain 3/8 GAS
	E3	Cover per RV external drain 3/8 GAS, holes M5
	E6	Cover per RV external drain 3/4-16UNF-2B
	I1	Cover per RV internal drain
	I3	Cover per RV internal drain for 03 flange only
Gr. 3	P1	Standard cover for pump

Motors		
Group 1	P1	Standard cover for unidirectional motor
	M1	Std. cover for motor drain M12x1.5
	M2	Cover for motor drain 1/8 GAS
	M3	Cover for motor drain 1/4 GAS
	M6	Cover for motor drain 7/16-20UNF-2B
Group 2	MH	Cover for motor drain M12x1,5 ISO6149
	P1	Std. cover for unidirectional motor
	L1	Cover for motor-side drain in vertical axis 1/4 Gas
	L6	Cover for motor-side drain in vertical axis 9/16-18UNF-2B
	M1	Std. cover for motor drain 1/4 GAS driven side
	M3	Cover for motor drain 1/4 GAS + holes M5 (03 flange only)
Group 3	M6	Standard cover for motor drain 9/16-18UNF-2B
	P1	Std. cover for unidirectional motor
	M1	Standard cover for motor drain M14x1.5
	M6	Cover for motor drain 9/16-18UNF-2B

#### G Inlet port

#### H Outlet port

A2	18,5x22,23x47,63x 3/8-16UNC	SAE flanged port
A3	25x26,19x52,37x 3/8-16UNC	
A4	31x30,18x58,72x 7/16-14UNC	
A5	37,5x35,7x69,85x 1/2-13UNC	
B1	8x30xM6	
B2	13x30xM6	Flanged port 4 threaded holes in X pattern, in center or off-set of body
B5	15x35xM6	
B6	15x40xM6	
B7	20x40xM6	
BA	18x55xM8	
BB	27x55xM8	
BC	36x55xM8	
C1	8x26xM5	
C2	12x26xM5	Flanged port 4 threaded holes in + pattern (European standard ports)
C3	13,5x30xM6	
C5	13,5x40xM8	
C7	20x40xM8	
C8	23,5x40xM8	
CA	27x51xM10	
CD	36x62xM10	

D1	M10x1	Threaded metric port
D3	M14x1,5	
D4	M16x1,5	
D5	M18x1,5	
D7	M22x1,5	
D9	M26x1,5	Threaded SAE O-ring boss port
E3	9/16-18UNF	
E4	3/4-16UNF	
E5	7/8-14UNF	
E6	1 1/16-12UN	
E8	1 5/16-12UN	
E9	1 3/8-12UN	
EA	1 7/8-12UN	Threaded GAS (BSPP) port
F2	1/4 GAS	
F3	3/8 GAS	
F4	1/2 GAS	
F5	3/4 GAS	
F6	1 GAS	
F7	1 1/4 GAS	

Model code for single pumps and motors (continued)

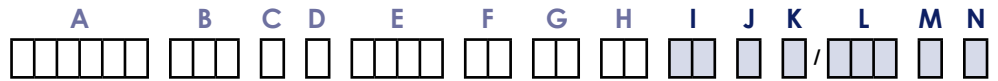

**I** Port position and variant body

<b>NN</b>	Std from catalogue
<b>YY</b>	Port Bx-Bx for flange SAE off-set from center of body as per catalogue
<b>ZZ</b>	Port type Bx-Bx in the center of the body

**J** Sealing

<b>N</b>	Standard Buna seal
<b>A</b>	Without shaft seal
<b>B</b>	VITON seal

**K** Screws

<b>N</b>	Standard screws
<b>A</b>	Galvanized screws+nuts-washers
<b>B</b>	DACROMET/GEOMET screws

**L** Set valve

<b>NNN</b>	No valve
<b>V**</b>	Integral RV-pressure setting. Pump/motor speed for relief valve setting (min <sup>-1</sup> [rpm]); Group 1 and 2

**M** Marking

<b>N</b>	Standard marking
<b>A</b>	Standard marking + Customer Code
<b>Z</b>	Without marking

**N** Mark position

<b>N</b>	Standard marking position
<b>A</b>	Mark on the bottom ref. to drive gear

# General Aluminum Gear Pumps and Motors

## Technical Information

### Group 0.5

#### Overview

TFP0NN pumps provide flexibility, numerous displacements, features, and shaft/port options. The TFP0NN series has earned an excellent reputation for rugged, dependable performance at continuous pressures and speeds.

TFP0NN pumps are available in five displacements from 0.25 to 1.27 cm<sup>3</sup>/rev [0.015 to 0.075 in<sup>3</sup>/rev]. Complete information can be found by referring to the specific sections in this technical manual.

TFP0NN 01FA



#### Design

Constructed of high strength aluminum, the TFP0NN rotation is either clockwise or counterclockwise.

TFP0NN 01FA (cut-away)



#### Features

Special features of Group 0.5 pumps include:

- Wide range of displacements
- Parallel shaft ends
- Standard mounting flange (European, 2-bolt)
- European port options

#### Technical data

Technical data – Group 0.5 gear pumps

		Frame size				
		,25	,45	,57	,76	1,3
<b>Displacement</b>	cm <sup>3</sup> /rev [in <sup>3</sup> /rev]	0.25 [0.015]	0.45 [0.027]	0.57 [0.034]	0.76 [0.045]	1.27 [0.075]
<b>Peak pressure</b>		200 [2900]	200 [2900]	200 [2900]	200 [2900]	200 [2900]
<b>Rated pressure</b>	bar [psi]	180 [2600]	180 [2600]	180 [2600]	180 [2600]	180 [2600]
<b>Minimum pressure at maximum speed</b>		103 [1500]	103 [1500]	103 [1500]	103 [1500]	103 [1500]
<b>Minimum speed at 103 bar [1500 psi]</b>	min <sup>-1</sup> (rpm)	500	500	500	500	500
<b>Maximum speed</b>		8000	8000	8000	7000	5000
<b>Weight</b>	kg [lb]	0.40 [0.88]	0.45 [1.00]	0.46 [1.01]	0.47 [1.03]	0.48 [1.06]
<b>Moment of inertia of rotating components</b>	x 10 <sup>-6</sup> kg·m <sup>2</sup> [x 10 <sup>-6</sup> lb·ft <sup>2</sup> ]	0.425 [10.09]	0.544 [12.91]	0.621 [14.74]	0.737 [17.49]	1.049 [24.89]
<b>Theoretical flow at maximum speed</b>	l/min [US gal/min]	2.00 [0.53]	3.60 [0.95]	4.56 [1.20]	5.32 [1.41]	6.35 [1.68]

1 kg·m<sup>2</sup> = 23.68 lb·ft<sup>2</sup>

For applications requiring parameters beyond those listed above, contact TurollaOCG.

**Dimensions**

**TFP0NN – 01FA**

Available 01FA configuration only.

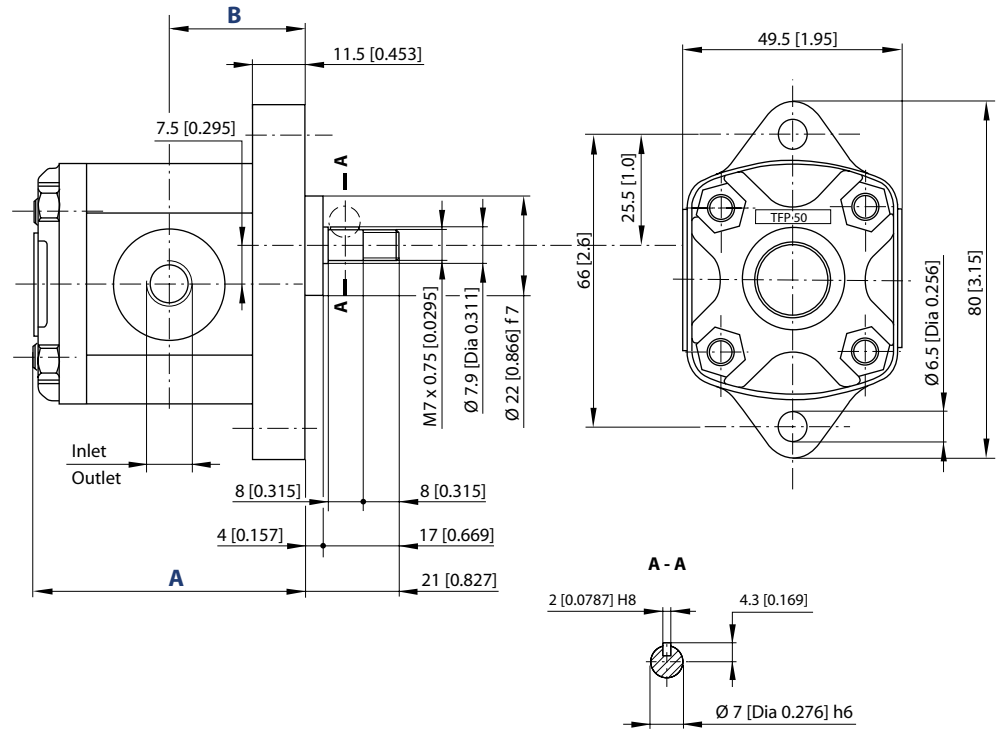

P005 052E

*TFP0NN dimensions*

Frame size		,25	,45	,57	,76	1,3
Dimension	A	53.5 [2.10]	55.0 [2.16]	56.0 [2.20]	61.5 [2.42]	61.5 [2.42]
	B	26.5 [1.04]	27.3 [1.07]	27.8 [1.09]	30.5 [1.20]	30.5 [1.20]
Input/Output		M10 x 1				

*Model code examples and maximum shaft torque*

Flange/drive gear	Model code example	Maximum shaft torque
01FA	TFP0NN/,57RN01FAP1D1D1NNNN/NNNN	4.5 N·m [39.8 lb·in]

For further details on ordering, see *Model Code*, pages 8÷11.

## General Aluminum Gear Pumps and Motors Technical Information Group 1

### Overview

TuroliaOCG group 1 gear pumps and motors use an external spur gear, and positive displacement design of proven high pressure and efficiency. These high performance pumps are robustly constructed. Their durability has been proven, with many years experience, in hydraulic products for mobile and industrial applications.

Group 1 enjoy a pressure-balanced design that provides high efficiency for the entire series. Series includes the SKP1NN, SEP1NN and SNP1NN pumps, and SKM1NN motor.

### Group 1 gears representatives

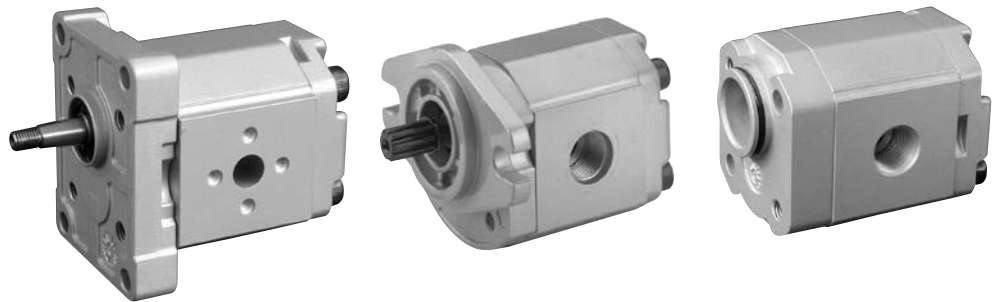

### Design

Group 1 is made up of high performance gear pumps and motors with fixed displacements. They are available with a variety of splined, parallel, and tapered shaft ends (not all are available with all flange styles); see *the table on shaft availability and interchangeability* on the next page. Various port configurations are also available. The SKM1NN motor can work in series.

SNP1NN 01BA, SNP1IN 03CA

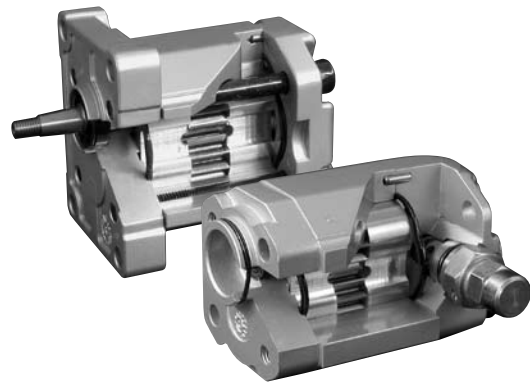

### Features

Special features of Group 1 pumps and motor include:

- wide range of displacements (from 1.2 to 12 cm<sup>3</sup>/rev [0.072 to 0.732 in<sup>3</sup>/rev] for pumps; from 2.6 to 12 cm<sup>3</sup>/rev [0.158 to 0.732 in<sup>3</sup>/rev] for motors)
- a variety of splined, parallel, and tapered shaft ends
- various standard mounting flanges
- European, DIN, O-ring boss, and BSPP (gas threaded) port options
- multiple pump configurations, in combination with SNP1NN, SKP1NN, SNP2NN, SKP2NN and SNP3NN.

### Technical data for pumps

#### Technical data – Group 1 gear pumps

Frame size		1,2	1,7	2,2	2,6	3,2	3,8	4,3	6,0	7,8	010	012
Displacement	cm <sup>3</sup> /rev [in <sup>3</sup> /rev]	1.18 [0.072]	1.57 [0.096]	2.09 [0.128]	2.62 [0.160]	3.14 [0.192]	3.66 [0.223]	4.19 [0.256]	5.89 [0.359]	7.59 [0.463]	9.94 [0.607]	12.00 [0.732]
<b>SNP1NN</b>												
Peak pressure	bar [psi]	270 [3915]	270 [3915]	270 [3915]	270 [3915]	270 [3915]	270 [3915]	270 [3915]	210 [3045]	170 [2465]	-	-
Rated pressure		250 [3625]	250 [3625]	250 [3625]	250 [3625]	250 [3625]	250 [3625]	250 [3625]	250 [3625]	190 [2760]		
Minimum speed at 0-150 bar	min <sup>-1</sup> (rpm)	800	800	600	600	600	600	500	500	500		
Min. speed at 150 bar to rated pressure		1200	1200	1000	1000	1000	1000	800	800	800		
Maximum speed		4000	4000	4000	4000	4000	4000	3000	3000	3000		
<b>SEP1NN</b>												
Peak pressure	bar [psi]	230 [3335]	230 [3335]	230 [3335]	230 [3335]	230 [3335]	230 [3335]	230 [3335]	190 [2760]	160 [2320]	-	-
Rated pressure		210 [3045]	210 [3045]	210 [3045]	210 [3045]	210 [3045]	210 [3045]	210 [3045]	210 [3045]	170 [2465]		
Minimum speed at 0-150 bar	min <sup>-1</sup> (rpm)	800	800	600	600	600	600	500	500	500		
Min. speed at 150 bar to rated pressure		1200	1200	1000	1000	1000	1000	800	800	800		
Maximum speed		4000	4000	4000	4000	4000	4000	3000	3000	3000		
<b>SKP1NN*</b>												
Peak pressure	bar [psi]	270 [3915]	270 [3915]	270 [3915]	270 [3915]	270 [3915]	270 [3915]	270 [3915]	250 [3625]	220 [3190]	170 [2465]	140 [2030]
Rated pressure		250 [3625]	250 [3625]	250 [3625]	250 [3625]	250 [3625]	250 [3625]	250 [3625]	250 [3625]	230 [3335]	200 [2900]	150 [2175]
Minimum speed at 0-150 bar	min <sup>-1</sup> (rpm)	800	800	800	800	800	800	600	600	600	600	600
Min. speed at 150 bar to rated pressure		1200	1200	1000	1000	1000	1000	1000	800	800	800	-
Maximum speed		4000	4000	4000	4000	4000	4000	3000	3000	3000	2000	2000
<b>All (SNP1NN, SEP1NN, SKP1NN)</b>												
Weight	kg [lb]	1.02 [2.26]	1.05 [2.31]	1.09 [2.40]	1.11 [2.45]	1.14 [2.51]	1.18 [2.60]	1.20 [2.65]	1.30 [2.87]	1.39 [3.06]	1.55 [3.42]	1.65 [3.64]
Moment of inertia of rotating components	x 10 <sup>-6</sup> kg·m <sup>2</sup> [x 10 <sup>-6</sup> lb·ft <sup>2</sup> ]*	3.2 [77]	3.7 [89]	4.4 [105]	5.1 [120]	5.7 [136]	6.4 [152]	7.1 [168]	9.3 [220]	11.4 [271]	14.6 [347]	17.1 [407]
Theoretical flow at maximum speed	l/min [US gal/min]	4.72 [1.25]	6.28 [1.66]	8.36 [2.21]	10.48 [2.77]	12.56 [3.32]	14.64 [3.87]	12.57 [3.32]	17.67 [4.67]	22.77 [6.02]	19.88 [5.25]	24 [6.34]

\* 1 kg·m<sup>2</sup> = 23.68 lb·ft<sup>2</sup>

This table details Group 1 technical data for gear pumps based on the model and displacement configuration. For further information, please see TurolaOCG publication *Group 1 Gear Pumps Technical Information*, **L1016399**.

\* SKP1NN is a special version of the SNP1NN. It is designed to accommodate an SAE 9T 20/40 DP tooth splined shaft for higher torque applications.

#### ⚠ Caution

The rated and peak pressure mentioned are for pumps with flanged ports only. When threaded ports are required a de-rated performance has to be considered. To verify the compliance of an high pressure application with a threaded ports pump apply to a TurolaOCG representative.

## Technical data for motors

### Technical data – Group 1 gear motors

Frame size		2,6	3,2	3,8	4,3	6,0	7,8	010	012
Displacement	cm <sup>3</sup> /rev	2.62	3.14	3.66	4.19	5.89	7.59	9.94	12
	[in <sup>3</sup> /rev]	[0.158]	[0.195]	[0.231]	[0.262]	[0.366]	[0.464]	[0.607]	[0.732]
<b>SKM1NN (standard, bi-directional motor)</b>									
Peak pressure	bar [psi]	270	270	270	270	250	220	180	150
		[3915]	[3915]	[3915]	[3915]	[3625]	[3190]	[2610]	[2175]
Rated pressure	bar [psi]	250	250	250	250	230	200	160	130
		[3625]	[3625]	[3625]	[3625]	[3335]	[2900]	[2320]	[1895]
Minimum speed	min <sup>-1</sup> (rpm)	1000	1000	1000	800	800	800	800	800
Maximum speed		4000	4000	3000	3000	2000	2000	2000	2000
<b>SKU1NN (standard, uni-directional motor)</b>									
Peak pressure	bar [psi]	270	270	270	270	250	220	170	140
		[3915]	[3915]	[3915]	[3915]	[3625]	[3190]	[2465]	[2030]
Rated pressure	bar [psi]	250	250	250	250	230	200	150	120
		[3625]	[3625]	[3625]	[3625]	[3335]	[2900]	[2175]	[1740]
Minimum speed	min <sup>-1</sup> (rpm)	1000	1000	1000	800	800	800	800	800
Maximum speed		4000	4000	3000	3000	2000	2000	2000	2000
<b>Both (SKM1NN and SKU1NN)</b>									
Weight	kg [lb]	1.02	1.14	1.18	1.2	1.3	1.39	1.55	1.65
		[2.26]	[2.51]	[2.60]	[2.65]	[2.87]	[3.06]	[3.42]	[3.64]
Moment of inertia of rotating components	x 10 <sup>-6</sup> kg·m <sup>2</sup>	5.1	5.7	6.4	7.1	9.3	11.4	14.6	17.1
	[x 10 <sup>-6</sup> lb·ft <sup>2</sup> ]	[121]	[135.2]	[151.9]	[168.5]	[220.7]	[270.5]	[339.4]	[405.8]

1 kg·m<sup>2</sup> = 23.68 lb·ft<sup>2</sup>

This table details Group 1 technical data for gear motors based on the model and displacement configuration. For

further information, please see TurollaOCG publication *Group 1, 2 and 3 Gear Motors, Technical Information, L1016082*.

### ⓘ Caution

The rated and peak pressure mentioned are for motors with flanged ports only. When threaded ports are required a de-rated performance has to be considered. To verify the compliance of an high pressure application with a threaded ports pump apply to a TurollaOCG representative.



**Gear pump dimensions SNP1NN – 01BA and 01DA**

This drawing shows the standard porting for 01BA and 01DA.  
Available in Series SNP1NN only.

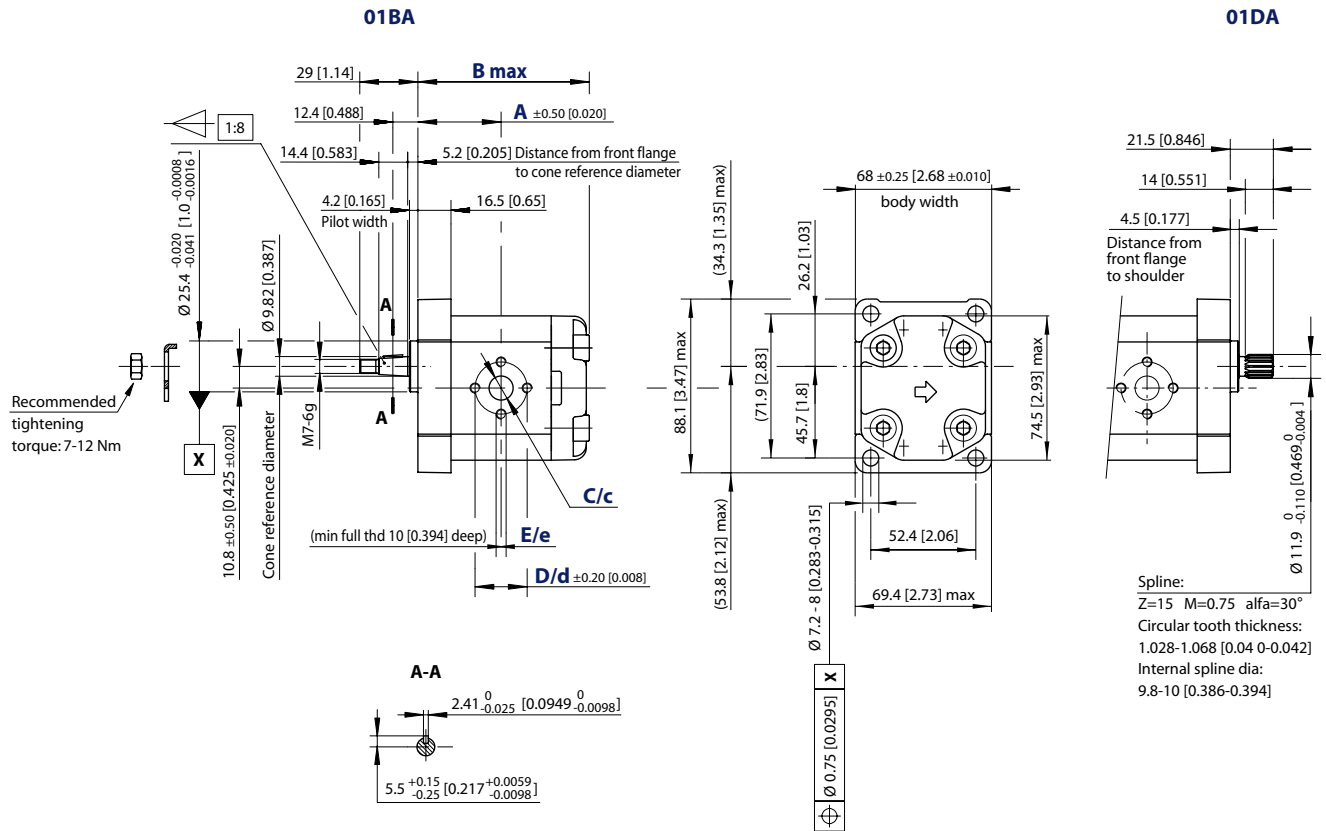

*SNP1NN – 01BA and 01DA dimensions*

Frame size		1,2	1,7	2,2	2,6	3,2	3,8	4,3	6,0	7,8
Dimension	A	37.75 [1.486]	38.5 [1.516]	39.5 [1.555]	40.5 [1.634]	41.5 [1.634]	42.5 [1.673]	43.5 [1.713]	46.75 [1.841]	50.0 [1.969]
	B	79.5 [3.130]	81.0 [3.189]	83.0 [3.268]	85.0 [3.346]	87.0 [3.425]	89.0 [3.504]	91.0 [3.583]	97.5 [3.839]	104.0 [4.094]
Inlet/Outlet	C/c	12 [0.472]								
	D/d	26 [1.024]								
	E/e	M5								

*Model code examples and maximum shaft torque*

Flange/drive gear	Model code example	Maximum shaft torque
01BA	SNP1NN/3,8RN01BAP1C2C2NNNNN/NNNNN	25 N•m [221 lb•in]
01DA	SNP1NN/6,0LN01DAP1C2C2NNNNN/NNNNN	35 N•m [310 lb•in]

For further details on ordering, see *Model Code*, pages 8÷11.

### Gear pump dimensions (continued)

### SKP1NN – 02BB and 02FA

This drawing shows the standard porting for 02BB and 02FA.  
Available in Series SKP1NN only.

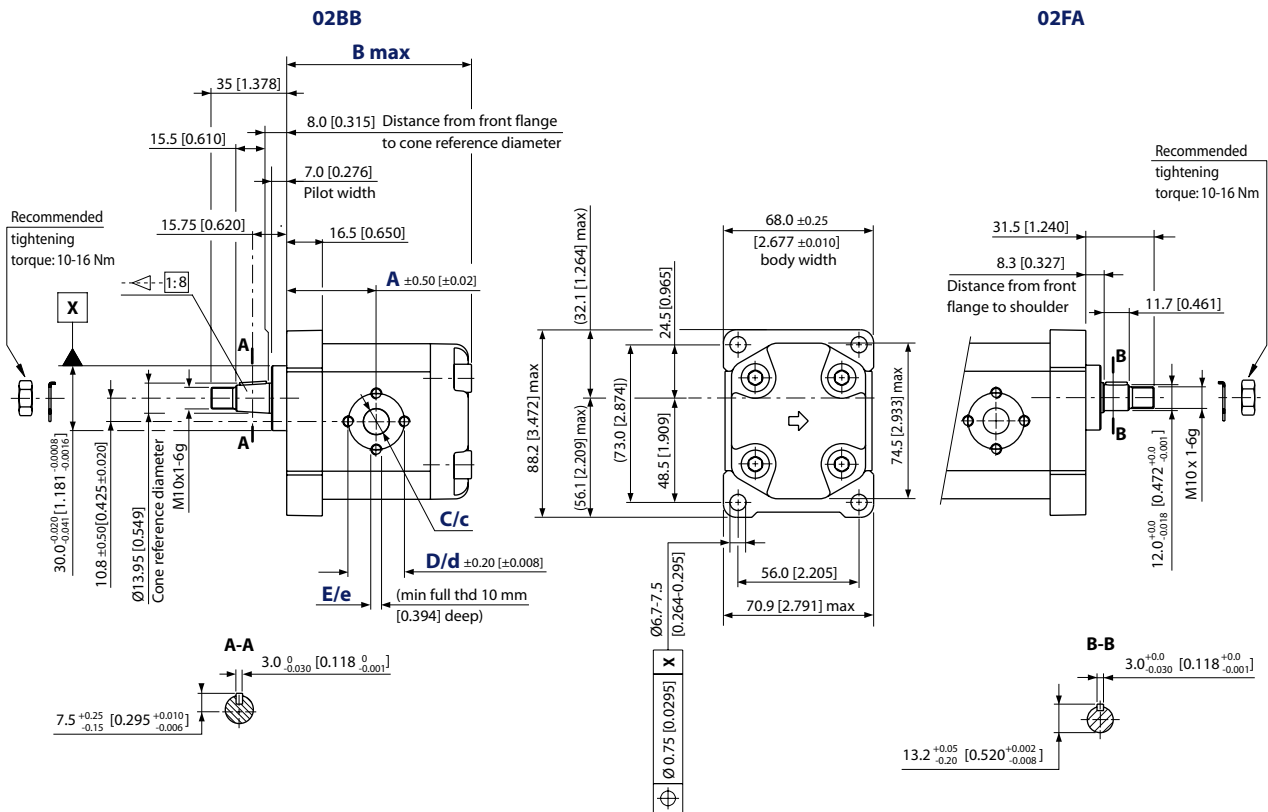

### SKP1NN – 02BB and 02FA dimensions

Frame size		1,2	1,7	2,2	2,6	3,2	3,8	4,3	6,0	7,8	010	012
Dimension	A	37.75 [1.486]	38.5 [1.516]	39.5 [1.555]	40.5 [1.634]	41.5 [1.634]	42.5 [1.673]	43.5 [1.713]	46.75 [1.841]	50.0 [1.969]	54.5 [2.146]	58.5 [2.303]
	B	79.5 [3.130]	81.0 [3.189]	83.0 [3.268]	85.0 [3.346]	87.0 [3.425]	89.0 [3.504]	91.0 [3.583]	97.5 [3.839]	104.0 [4.094]	113.0 [4.449]	121.0 [4.764]
Inlet/Outlet	C/c	12 [0.472]										
	D/d	26 [1.024]										
	E/e	M5										

### Model code examples and maximum shaft torque

Flange/drive gear	Model code example	Maximum shaft torque
02BB	SKP1NN/6,ORN02BBP1C2C2NNNNN/NNNNN	50 N·m [442 lb·in]
02FA	SKP1NN/ 2,2LN02FAP1C2C2NNNNN/NNNNN	24 N·m [212 lb·in]

For further details on ordering, see [Model Code](#), pages 8÷11.

**Gear pump dimensions  
(continued)**

**SNP1NN, SEP1NN – 03CA**

This drawing shows the standard porting for 03CA.

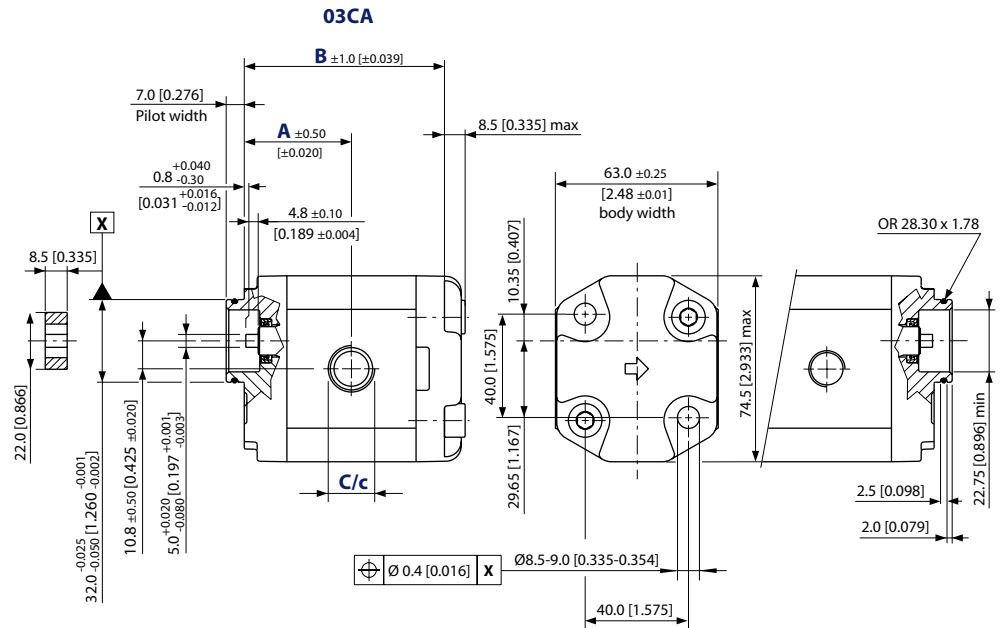

*SNP1NN, SEP1NN – 03CA dimensions*

Frame size		1,2	1,7	2,2	2,6	3,2	3,8	4,3	6,0	7,8
Dimension	A	37.75 [1.486]	38.5 [1.516]	39.5 [1.555]	40.5 [1.634]	41.5 [1.634]	42.5 [1.673]	43.5 [1.713]	46.75 [1.841]	50 [1.969]
	B	70 [2.756]	71.5 [2.815]	73.5 [2.894]	75.5 [2.972]	77.5 [3.051]	79.5 [3.130]	81.5 [3.209]	88.0 [3.465]	94.5 [3.720]
Inlet	C	M18 x 1.5 THD 12 [0.472] deep								
Outlet	c	M14 x 1.5, THD 12 [0.472] deep				M18 x 1.5, THD 12 [0.472] deep				

*Model code examples and maximum shaft torque*

Flange/drive gear	Model code example	Maximum shaft torque
03CA	SNP1NN/1,7RN03CA03D5D3NNNNN/NNNNN	14 N•m [124 lb•in]
	SEP1NN/2,2LN03CA03D5D3NNNNN/NNNNN	

For further details on ordering, see *Model Code*, pages 8÷11.

### Gear pump dimensions (continued)

### SKP1NN – 06GA and 06SA

This drawing shows the standard porting for 06GA and 06SA.  
Available in Series SKP1NN only.

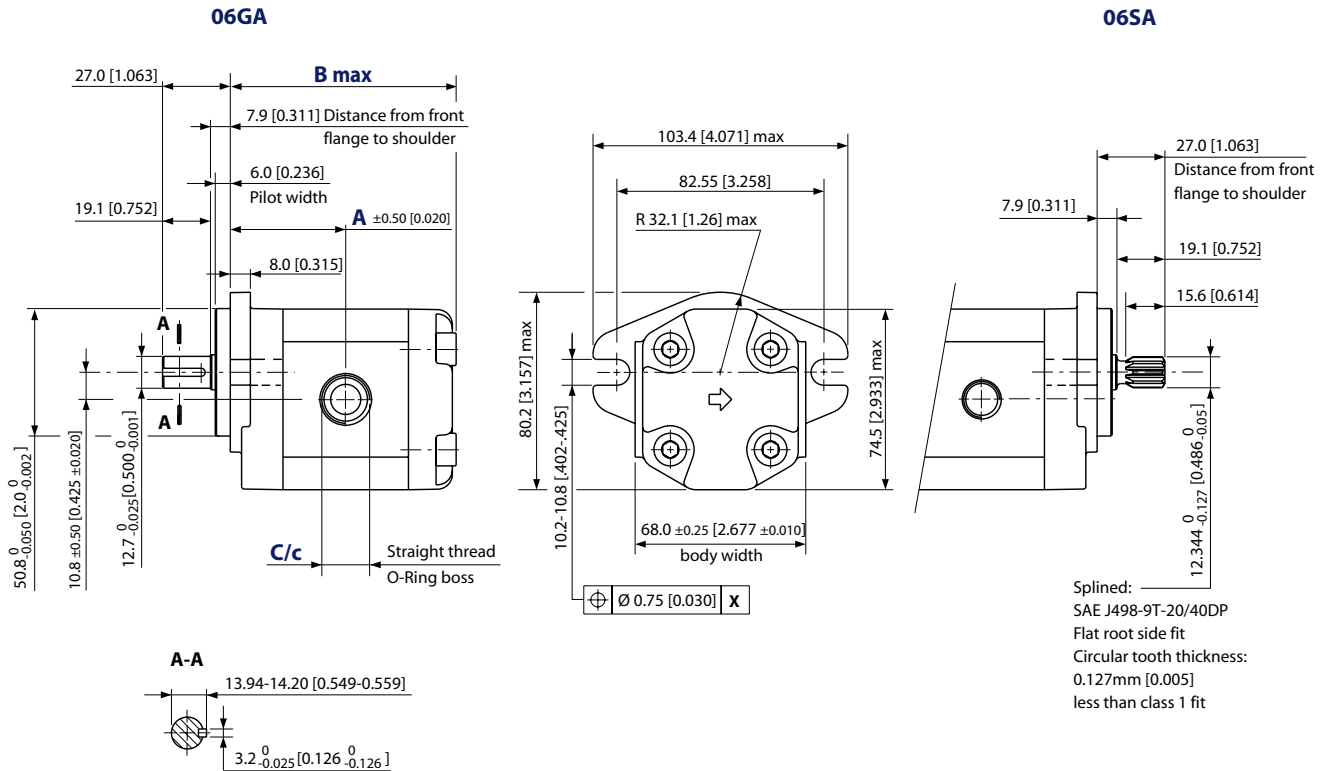

### SKP1NN – 06GA and 06SA dimensions

Frame size		1,2	1,7	2,2	2,6	3,2	3,8	4,3	6,0	7,8	010	012
Dimension	A	42.25 [1.663]	43 [1.693]	44 [1.732]	45.0 [1.772]	46.0 [1.811]	47 [1.850]	48 [1.890]	51.25 [2.018]	54.5 [2.146]	59 [2.323]	63.5 [2.50]
	B	84 [3.307]	85.5 [3.366]	87.5 [3.445]	89.5 [3.524]	91.5 [3.602]	93.5 [3.681]	95.5 [3.760]	102 [4.016]	108.5 [4.272]	117.5 [4.626]	125.5 [4.941]
Inlet	C	3/4–16UNF–2B, THD 14.3 [0.563] deep										
Outlet	c	9/16–18UNF–2B, THD 12.7 [0.500] deep										

### Model code examples and maximum shaft torque

Flange/drive gear	Model code example	Maximum shaft torque
06GA	SKP1NN/3,2RN06GAP1E4E3NNNN/NNNN	32 N·m [283 lb·in]
06SA	SKP1NN/012LN06SAP1E4E3NNNN/NNNN	34 N·m [301 lb·in]

For further details on ordering, see *Model Code*, pages 8÷11.

**Gear motor dimensions SKM1NN – 01BA**

This drawing shows the standard porting for 01BA.  
Available in Series SKM1NN only.

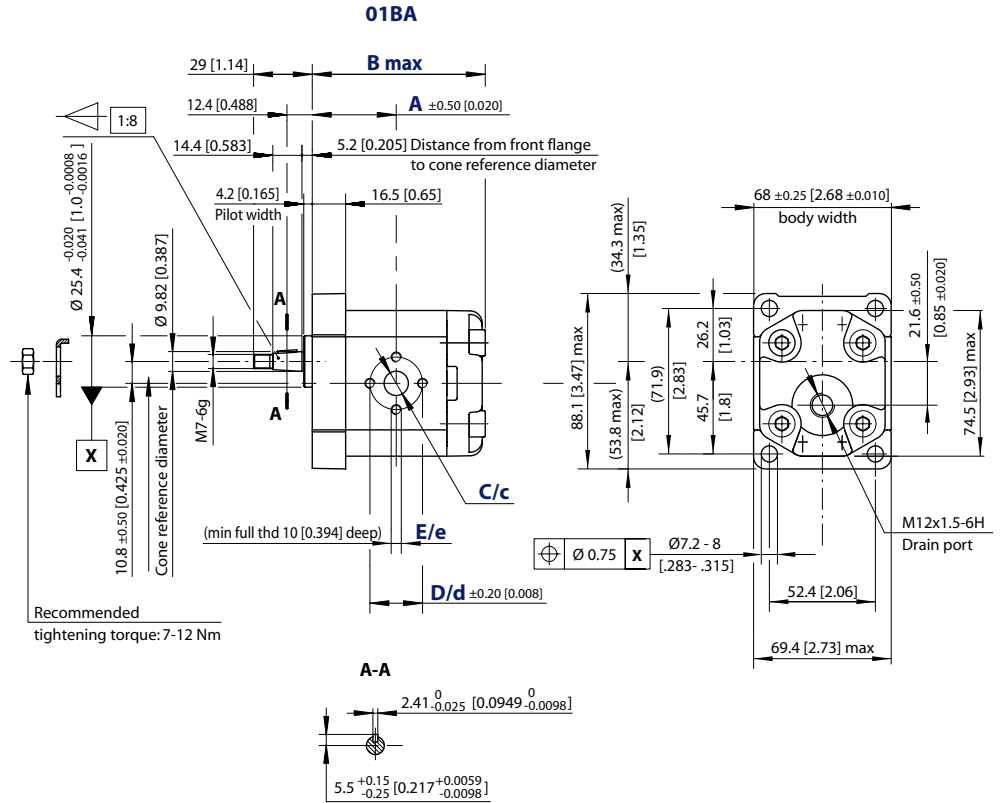

*SKM1NN – 01BA dimensions*

Frame size		2,6	3,2	3,8	4,3	6,0	7,8	010	012
Dimension	<b>A</b>	40.5 [1.594]	41.5 [1.634]	42.5 [1.673]	43.5 [1.713]	46.75 [1.841]	50 [1.969]	54.5 [2.146]	58.5 [2.303]
	<b>B</b>	85 [3.346]	87 [3.425]	89 [3.504]	91 [3.583]	97.5 [3.839]	104 [4.094]	113 [4.449]	121 [4.764]
Inlet/Outlet	<b>C/c</b>	12 [0.472]							
	<b>D/d</b>	26 [1.024]							
	<b>E/e</b>	M5							

*Model code examples and maximum shaft torque*

Flange/drive gear	Model code example	Maximum shaft torque
<b>01BA</b>	SKM1NN/3,2BN01BAM1C2C2NNNN/NNNNN	25 N•m [221 lb•in]

For further details on ordering, see *Model Code*, pages 8÷11.

### Gear motor dimensions (continued)

### SKM1NN, SKU1NN – 02BB and 02FA

This drawing shows the standard porting for 02BB and 02FA.

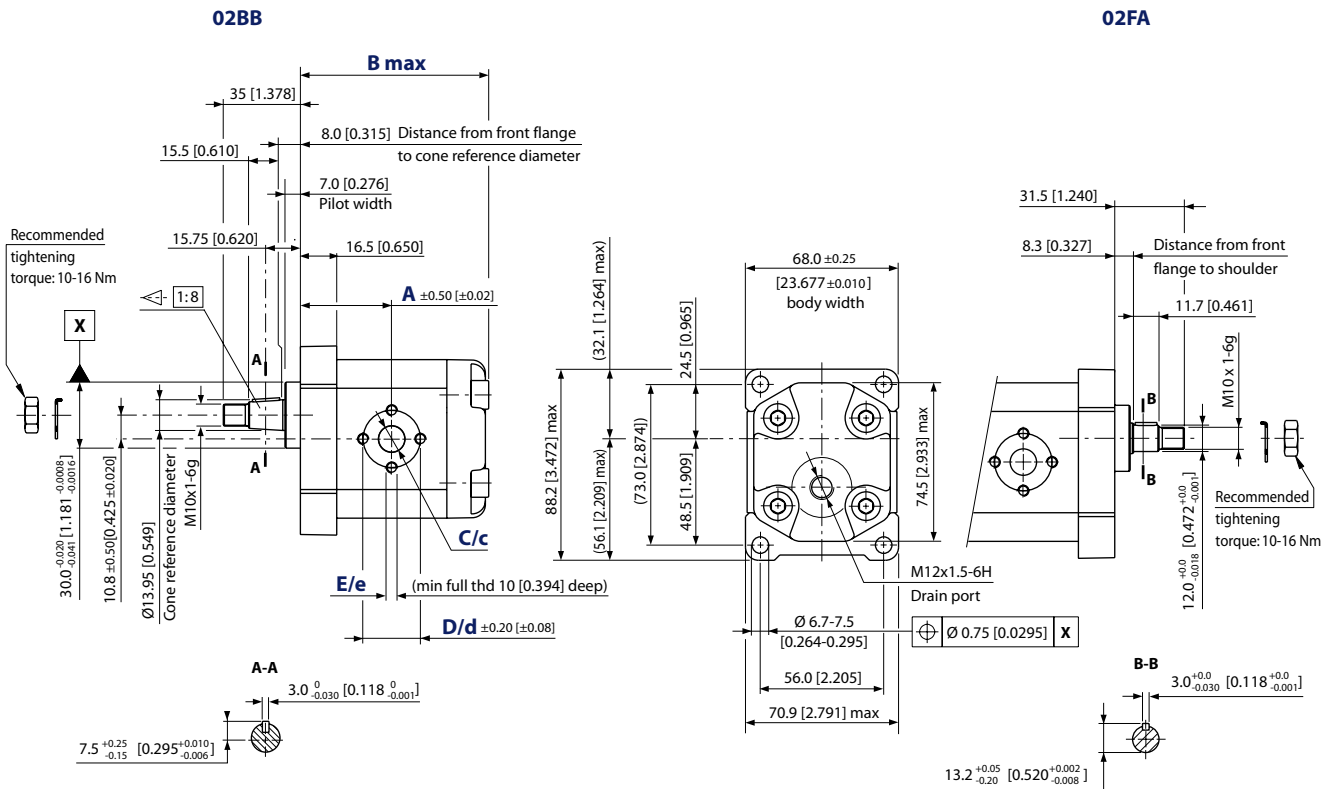

### SKM1NN, SKU1NN – 02BB and 02FA dimensions

Frame size		2,6	3,2	3,8	4,3	6,0	7,8	010	012
Dimension	A	40.5 [1.594]	41.5 [1.634]	42.5 [1.673]	43.5 [1.713]	46.75 [1.841]	50 [1.969]	54.5 [2.146]	58.5 [2.303]
	B	85 [3.346]	87 [3.425]	89 [3.504]	91 [3.583]	97.5 [3.839]	104 [4.094]	113 [4.449]	121 [4.764]
Inlet/Outlet	C/c	12 [0.472]							
	D/d	26 [1.024]							
	E/e	M5							

### Model code examples and maximum shaft torque

Flange/drive gear	Model code example	Maximum shaft torque
02BB	SKM1NN/010BN02BBM1C2C2NNNN/NNNNN SKU1NN/6,0LN02BBM1C2C2NNNN/NNNNN	50 N·m [442 lb·in]
02FA	SKM1NN/6,0BN02FAM1C2C2NNNN/NNNNN SKU1NN/6,0LN02FAM1C2C2NNNN/NNNNN	24 N·m [212 lb·in]

For further details on ordering, see [Model Code](#), pages 8÷11.

### Gear motor dimensions (continued)

### SKM1NN – 06GA and 06SA

This drawing shows the standard porting for 06GA and 06SA.  
Available in Series SKM1NN only.

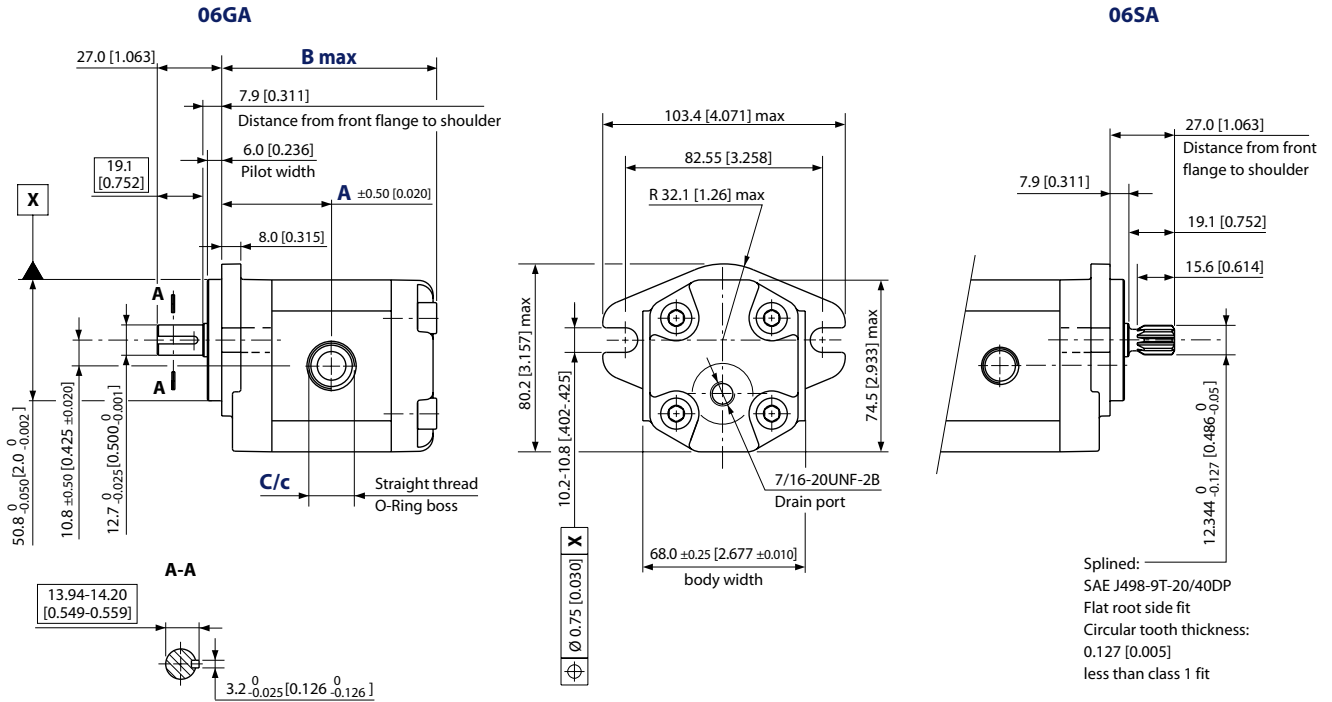

### SKM1NN – 06GA and 06SA dimensions

Frame size		2,6	3,2	3,8	4,3	6,0	7,8	010	012
Dimension	<b>A</b>	45 [1.771]	46 [1.811]	47 [1.85]	48 [1.889]	51.25 [2.017]	54.5 [2.145]	59 [2.322]	63.5 [2.5]
	<b>B</b>	89.5 [3.523]	91.5 [3.602]	93.5 [3.681]	95.5 [3.759]	102 [4.015]	108.5 [4.271]	117.5 [4.625]	125.5 [4.94]
Inlet/Outlet	<b>C/c</b>	¾-16UNF-2B, THD 14.3 [0.563] deep							

### Model code examples and maximum shaft torque

Flange/drive gear	Model code example	Maximum shaft torque
<b>06GA</b>	SKM1NN/6,0BN06GAM6E4E4NNNN/NNNNN	32 N•m [283 lb•in]
<b>06SA</b>	SKM1NN/012BN06SAM6E4E4NNNN/NNNNN	34 N•m [301 lb•in]

For further details on ordering, see *Model Code*, pages 8÷11.

### Group 1 pump ports

Available pump ports for Group 1

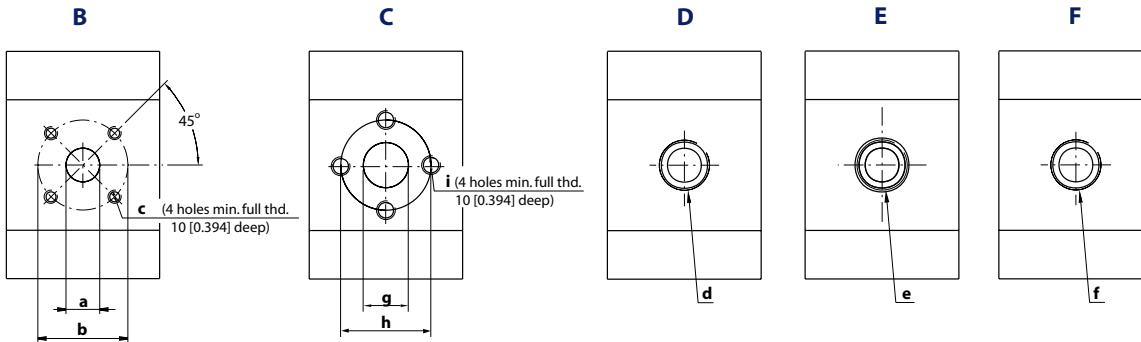

Dimensions of Group 1 pumps ports

Port type		B			C			D	E	F	
Port dimensions		a	b	c	g	h	i	d	e	f	
Frame size	1,2	Inlet	13 [0.512]	30 [1.181]	M6	12 [0.462]	26 [1.024]	M5	M18x1.5	3/4-16UNF-2B	3/8 Gas (BSPP)
		Outlet	8 [0.315]	30 [1.181]	M6	12 [0.462]	26 [1.024]	M5	M18x1.5	9/16-18UNF-2B	3/8 Gas (BSPP)
	1,7	Inlet	13 [0.512]	30 [1.181]	M6	12 [0.462]	26 [1.024]	M5	M18x1.5	3/4-16UNF-2B	3/8 Gas (BSPP)
		Outlet	8 [0.315]	30 [1.181]	M6	12 [0.462]	26 [1.024]	M5	M18x1.5	9/16-18UNF-2B	3/8 Gas (BSPP)
	2,2	Inlet	13 [0.512]	30 [1.181]	M6	12 [0.462]	26 [1.024]	M5	M18x1.5	3/4-16UNF-2B	3/8 Gas (BSPP)
		Outlet	8 [0.315]	30 [1.181]	M6	12 [0.462]	26 [1.024]	M5	M18x1.5	9/16-18UNF-2B	3/8 Gas (BSPP)
	2,6	Inlet	13 [0.512]	30 [1.181]	M6	12 [0.462]	26 [1.024]	M5	M18x1.5	3/4-16UNF-2B	3/8 Gas (BSPP)
		Outlet	8 [0.315]	30 [1.181]	M6	12 [0.462]	26 [1.024]	M5	M18x1.5	9/16-18UNF-2B	3/8 Gas (BSPP)
	3,2	Inlet	13 [0.512]	30 [1.181]	M6	12 [0.462]	26 [1.024]	M5	M18x1.5	3/4-16UNF-2B	3/8 Gas (BSPP)
		Outlet	8 [0.315]	30 [1.181]	M6	12 [0.462]	26 [1.024]	M5	M18x1.5	9/16-18UNF-2B	3/8 Gas (BSPP)
	3,8	Inlet	13 [0.512]	30 [1.181]	M6	12 [0.462]	26 [1.024]	M5	M18x1.5	3/4-16UNF-2B	3/8 Gas (BSPP)
		Outlet	8 [0.315]	30 [1.181]	M6	12 [0.462]	26 [1.024]	M5	M18x1.5	9/16-18UNF-2B	3/8 Gas (BSPP)
4,3	Inlet	13 [0.512]	30 [1.181]	M6	12 [0.462]	26 [1.024]	M5	M18x1.5	3/4-16UNF-2B	3/8 Gas (BSPP)	
	Outlet	8 [0.315]	30 [1.181]	M6	12 [0.462]	26 [1.024]	M5	M18x1.5	9/16-18UNF-2B	3/8 Gas (BSPP)	
6,0	Inlet	13 [0.512]	30 [1.181]	M6	12 [0.462]	26 [1.024]	M5	M18x1.5	3/4-16UNF-2B	3/8 Gas (BSPP)	
	Outlet	13 [0.512]	30 [1.181]	M6	12 [0.462]	26 [1.024]	M5	M18x1.5	9/16-18UNF-2B	3/8 Gas (BSPP)	
7,8	Inlet	13 [0.512]	30 [1.181]	M6	12 [0.462]	26 [1.024]	M5	M18x1.5	3/4-16UNF-2B	3/8 Gas (BSPP)	
	Outlet	13 [0.512]	30 [1.181]	M6	12 [0.462]	26 [1.024]	M5	M18x1.5	9/16-18UNF-2B	3/8 Gas (BSPP)	
010	Inlet	13 [0.512]	30 [1.181]	M6	12 [0.462]	26 [1.024]	M5	M18x1.5	3/4-16UNF-2B	3/8 Gas (BSPP)	
	Outlet	13 [0.512]	30 [1.181]	M6	12 [0.462]	26 [1.024]	M5	M18x1.5	9/16-18UNF-2B	3/8 Gas (BSPP)	
012	Inlet	13 [0.512]	30 [1.181]	M6	12 [0.462]	26 [1.024]	M5	M18x1.5	3/4-16UNF-2B	3/8 Gas (BSPP)	
	Outlet	13 [0.512]	30 [1.181]	M6	12 [0.462]	26 [1.024]	M5	M18x1.5	9/16-18UNF-2B	3/8 Gas (BSPP)	



**Group 1 motor ports**

Available ports for bi-directional motor SKM1NN

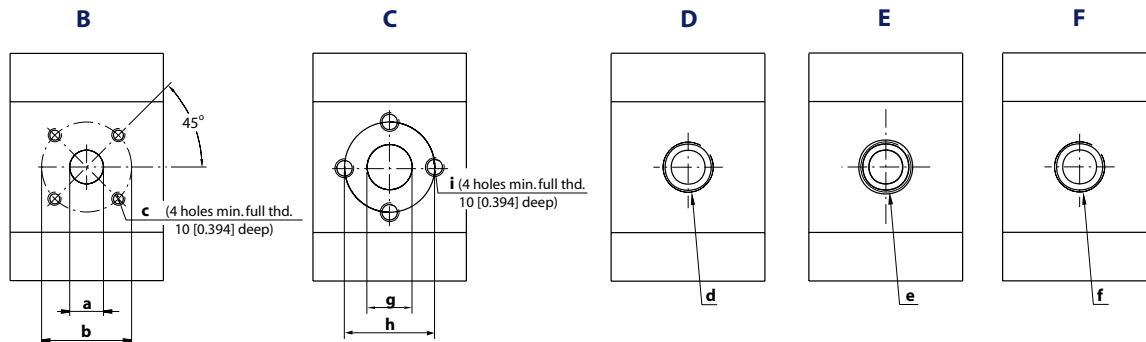

SKM1NN bi-directional motor ports dimensions (all frame sizes)

Port type	B			C			D	E	F
Port dimensions	a	b	c	g	h	i	d	e	f
Inlet/Outlet	13 [0.512]	30 [1.181]	M6	12 [0.472]	26 [1.024]	M5	M18x1.5	3/4-16UNF-2B	3/8 Gas (BSPP)
Drain	M12x1.5			M12x1.5			M12x1.5	7/16-20UNF-2B	1/8 Gas (BSPP)

SNU1NN, SKU1NN uni-directional motor ports dimensions

Port type	B			C			D	E	F		
Port dimensions	a	b	c	g	h	i	d	e	f		
Type (displacement)	2,6	Outlet	13 [0.512]	30 [1.181]	M6	12 [0.472]	26 [1.024]	M5	M18x1.5	3/4-16UNF-2B	3/8 Gas (BSPP)
		Inlet	8 [0.315]	30 [1.181]	M6	12 [0.472]	26 [1.024]	M5	M14x1.5	9/16-18UNF-2B	3/8 Gas (BSPP)
	3,2	Outlet	13 [0.512]	30 [1.181]	M6	12 [0.472]	26 [1.024]	M5	M18x1.5	3/4-16UNF-2B	3/8 Gas (BSPP)
		Inlet	8 [0.315]	30 [1.181]	M6	12 [0.472]	26 [1.024]	M5	M14x1.5	9/16-18UNF-2B	3/8 Gas (BSPP)
	3,8	Outlet	13 [0.512]	30 [1.181]	M6	12 [0.472]	26 [1.024]	M5	M18x1.5	3/4-16UNF-2B	3/8 Gas (BSPP)
		Inlet	8 [0.315]	30 [1.181]	M6	12 [0.472]	26 [1.024]	M5	M14x1.5	9/16-18UNF-2B	3/8 Gas (BSPP)
	4,3	Outlet	13 [0.512]	30 [1.181]	M6	12 [0.472]	26 [1.024]	M5	M18x1.5	3/4-16UNF-2B	3/8 Gas (BSPP)
		Inlet	8 [0.315]	30 [1.181]	M6	12 [0.472]	26 [1.024]	M5	M14x1.5	9/16-18UNF-2B	3/8 Gas (BSPP)
	6,0	Outlet	13 [0.512]	30 [1.181]	M6	12 [0.472]	26 [1.024]	M5	M18x1.5	3/4-16UNF-2B	3/8 Gas (BSPP)
		Inlet	13 [0.512]	30 [1.181]	M6	12 [0.472]	26 [1.024]	M5	M18x1.5	9/16-18UNF-2B	3/8 Gas (BSPP)
	7,8	Outlet	13 [0.512]	30 [1.181]	M6	12 [0.472]	26 [1.024]	M5	M18x1.5	3/4-16UNF-2B	3/8 Gas (BSPP)
		Inlet	13 [0.512]	30 [1.181]	M6	12 [0.472]	26 [1.024]	M5	M18x1.5	9/16-18UNF-2B	3/8 Gas (BSPP)
	010	Outlet	13 [0.512]	30 [1.181]	M6	12 [0.472]	26 [1.024]	M5	M18x1.5	3/4-16UNF-2B	3/8 Gas (BSPP)
		Inlet	13 [0.512]	30 [1.181]	M6	12 [0.472]	26 [1.024]	M5	M18x1.5	9/16-18UNF-2B	3/8 Gas (BSPP)
	012	Outlet	13 [0.512]	30 [1.181]	M6	12 [0.472]	26 [1.024]	M5	M18x1.5	3/4-16UNF-2B	3/8 Gas (BSPP)
		Inlet	13 [0.512]	30 [1.181]	M6	12 [0.472]	26 [1.024]	M5	M18x1.5	9/16-18UNF-2B	3/8 Gas (BSPP)

# General Aluminum Gear Pumps and Motors

## Technical Information

### Group 1

#### Shaft and flange availability

This table details the standard Group 1 shafts and flange combinations that are currently available with the maximum shaft torque limits. For further information, please see TurollaOCG publications *Group 1 Gear Pumps Technical Information*, **L1016399** and *Group 1, 2 and 3 Gear Motors, Technical Information*, **L1016082**.

#### Shaft and flange availability and torque capacity

Shaft Description	Code	Mounting flange code with maximum torque in N·m [lbf·in]			
		01	02	03	06
Taper 1:8	<b>BA</b>	25 [221]	–	–	–
Taper 1:8	<b>BB</b>	–	50 [442]	–	–
Spline T-15, m=0.75, alfa=30°	<b>DA</b>	35 [310]	–	–	–
SAE spline J 498-9T-20/40DP	<b>SA</b>	–	–	–	34 [301]
Parallel 12 mm [0.47 in]	<b>FA</b>	–	24 [212]	–	–
Parallel 12.7 mm [0.5 in]	<b>GA</b>	–	–	–	32 [283]
TurollaOCG Tang	<b>CA</b>	–	–	14 [124]	–

## General Aluminum Gear Pumps and Motors Technical Information Group 2

### Overview

TuroliaOCG' Group 2 family of gear pumps: SNP2NN, SKP2NN and motors: SNM2NN, SNU2NN, SKU2NN are pressure balanced to provide high efficiency for the entire series. The SNP2NN pump accommodates SAE 9-tooth and the SKP2NN pump accommodates SAE 11-tooth splined shaft for higher torque applications. The SNM2NN (a bi-directional motor) and the SNU2NN, SKU2NN (uni-directional motors) complete the family.

### *Group 2 gear pumps and motors*

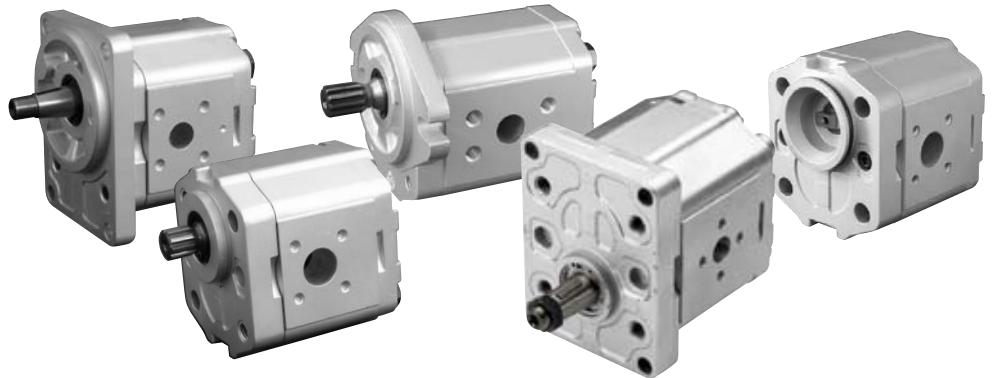

### Design

The Group 2 family of gear pumps and motors have a full range of mounting flanges meeting the standards of the market. The robust shaft seal design has a built-in stiffener and dust lip. The extruded aluminum alloy body is built for high pressure, complete with flanged or threaded ports that are compatible with market standards. Their patented sealing system design with high pressures and prevents leaks. SKP2NN are 11-tooth splined shaft gear pumps.

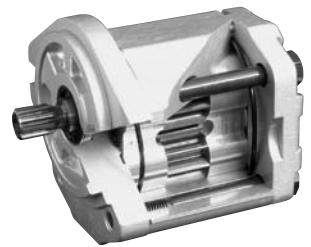

### Features

Special features within the Group 2 family include:

- wide range of displacement (from 4 to 25 cm<sup>3</sup>/rev [from 0.24 to 1.54 in<sup>3</sup>/rev] for pumps; and from 6 to 25 cm<sup>3</sup>/rev [from 0.36 to 1.54 in<sup>3</sup>/rev] for motors)
- various splined, parallel, and tapered shaft ends
- many types of industry-standard and special engine mounting flanges
- assorted port configurations including European, DIN standard, BSPP, and O-ring boss
- numerous relief valve options, including full-flow, pilot, and others
- outrigger bearing assembly available for high radial and thrust load applications
- multiple configurations in combination with SNP1NN, SKP1NN, SKP2NN and SNP3NN pumps.

## Technical data for pumps

### Technical data – Group 2 gear pumps

		Frame size								
		4,0	6,0	8,0	011	014	017	019	022	025
Displacement	cm <sup>3</sup> /rev [in <sup>3</sup> /rev]	3.9 [0.24]	6 [0.37]	8.4 [0.51]	10.8 [0.66]	14.4 [0.88]	16.8 [1.02]	19.2 [1.17]	22.8 [1.39]	25.2 [1.54]
<b>SNP2NN</b>										
Peak pressure	bar [psi]	280 [4060]	280 [4060]	280 [4060]	280 [4060]	280 [4060]	280 [4060]	230 [3335]	200 [2900]	175 [2638]
Rated pressure		250 [3625]	250 [3625]	250 [3625]	250 [3625]	250 [3625]	250 [3625]	250 [3625]	210 [3045]	180 [2610]
Minimum speed at 0-100 bar	min <sup>-1</sup> (rpm)	600	600	600	500	500	500	500	500	500
Minimum speed at 100-180 bar		1200	1200	1000	800	750	750	700	700	700
Min. speed at 180 bar to rated pressure		1400	1400	1400	1200	1000	1000	1000	800	–
Maximum speed		4000	4000	4000	4000	3500	3000	3000	3000	3000
<b>SKP2NN</b>										
Peak pressure	bar [psi]	280 [4060]	280 [4060]	280 [4060]	280 [4060]	280 [4060]	280 [4060]	260 [3770]	230 [3335]	200 [2900]
Rated pressure		250 [3625]	250 [3625]	250 [3625]	250 [3625]	250 [3625]	250 [3625]	250 [3625]	240 [3480]	210 [3045]
Minimum speed at 0-100 bar	min <sup>-1</sup> (rpm)	600	600	600	500	500	500	500	500	500
Minimum speed at 100-180 bar		1200	1200	1000	800	750	750	700	700	700
Min. speed at 180 bar to rated pressure		1400	1400	1400	1200	1000	1000	1000	800	800
Maximum speed		4000	4000	4000	4000	3500	3000	3000	3000	3000
<b>Both (SNP2NN, SKP2NN)</b>										
Weight	kg [lb]	2.3 [5.1]	2.4 [5.3]	2.5 [5.5]	2.7 [5.8]	2.9 [6.3]	3.0 [6.5]	3.1 [6.7]	3.2 [7]	3.3 [7.3]
Moment of inertia of rotating components	x 10 <sup>-6</sup> kg·m <sup>2</sup> [x 10 <sup>-6</sup> lb·ft <sup>2</sup> ]	21.3 [505]	26.5 [629]	32.4 [769]	38.4 [911]	47.3 [1122]	53.3 [1265]	59.2 [1405]	68.1 [1616]	74.1 [1758]
Theoretical flow at maximum speed	l/min [US gal/min]	15.6 [4.1]	24.0 [6.3]	33.6 [8.9]	43.2 [11.4]	50.4 [13.3]	50.4 [13.3]	57.6 [15.2]	68.4 [18]	75.6 [20]

$$1 \text{ kg}\cdot\text{m}^2 = 23.68 \text{ lb}\cdot\text{ft}^2$$

This table details Group 2 technical data for gear pumps based on the model and displacement configuration. For further information about application and configuration of gear pumps, please see TuroliaOCG publication *Group 2 Gear Pumps Technical Information*, **L1016341**.

### ⓘ Caution

The rated and peak pressure mentioned are for pumps with flanged ports only. When threaded ports are required a de-rated performance has to be considered. To verify the compliance of an high pressure application with a threaded ports pump apply to a TuroliaOCG representative.

## Technical data for motors

### Technical data – Group 2 gear motors

		Frame size							
		6,0	8,0	011	014	017	019	022	025
Displacement	cm <sup>3</sup> /rev [in <sup>3</sup> /rev]	6 [0.36]	8.4 [0.513]	10.8 [0.659]	14.4 [0.879]	16.8 [1.025]	19.2 [1.171]	22.8 [1.391]	25.2 [1.538]
<b>SNM2NN (bi-directional motor)</b>									
Peak pressure	bar [psi]	280 [4060]	280 [4060]	280 [4060]	280 [4060]	260 [3770]	230 [3335]	200 [2900]	180 [2610]
Rated pressure		250 [3625]	250 [3625]	250 [3625]	250 [3625]	230 [3335]	210 [3000]	180 [2610]	160 [2320]
Outlet pressure		250 [3625]	250 [3625]	250 [3625]	250 [3625]	230 [3335]	210 [3000]	180 [2610]	160 [2320]
Minimum speed	min <sup>-1</sup> (rpm)	700	700	700	700	500	500	500	500
Maximum speed		4000	4000	4000	4000	4000	3500	3500	3500
<b>SNU2NN (uni-directional motor)</b>									
Peak pressure	bar [psi]	-	280 [4060]	280 [4060]	280 [4060]	260 [3770]	230 [3335]	200 [2900]	180 [2610]
Rated pressure			250 [3625]	250 [3625]	250 [3625]	230 [3335]	210 [3000]	180 [2610]	160 [2320]
Minimum speed	min <sup>-1</sup> (rpm)		600	600	600	500	500	500	500
Maximum speed			3500	3500	3500	3000	3000	3000	2500
<b>SKU2NN (uni-directional motor)</b>									
Peak pressure	bar [psi]	-	280 [4060]	280 [4060]	280 [4060]	260 [3770]	230 [3335]	200 [2900]	175 [2815]
Rated pressure			250 [3625]	250 [3625]	250 [3625]	230 [3335]	210 [3000]	180 [2610]	160 [2320]
Minimum speed	min <sup>-1</sup> (rpm)		600	600	600	500	500	500	500
Maximum speed			3500	3500	3500	3000	3000	3000	2500
<b>All (SNM2NN, SNU2NN, SKU2NN)</b>									
Weight	kg [lb]	2.4 [5.3]	2.5 [5.5]	2.7 [5.5]	2.9 [6.3]	3.0 [6.5]	3.1 [6.7]	3.2 [7]	3.3 [7.3]
Moment of inertia of rotating components	x 10 <sup>-6</sup> kg·m <sup>2</sup> [x 10 <sup>-6</sup> lb·ft <sup>2</sup> ]	26.5 [629]	32.4 [769]	38.4 [911]	47.3 [1122]	53.3 [1265]	59.2 [1405]	68.1 [1616]	74.1 [1758]
Theoretical flow at maximum speed	l/min [US gal/min]	24 [6.3]	33.6 [8.9]	43.2 [11.4]	50.4 [13.3]	50.4 [13.3]	57.6 [15.2]	68.4 [180]	75.6 [20]

1 kg·m<sup>2</sup> = 23.68 lb·ft<sup>2</sup>

This table details the performance of the Group 2 gear motors. For further information about application and configuration of gear motors, please see TurollaOCG publication *Group 1, 2 and 3 Gear Motors, Technical Information*, **L1016082**.

### ⚠ Caution

The rated and peak pressure mentioned are for motors with flanged ports only. When threaded ports are required a de-rated performance has to be considered. To verify the compliance of an high pressure application with a threaded ports pump apply to a TurollaOCG representative.



**Gear pump dimensions (continued)**

**SNP2NN – 02DB and 02AA**

This drawing shows the standard porting for 02DB and 02AA.

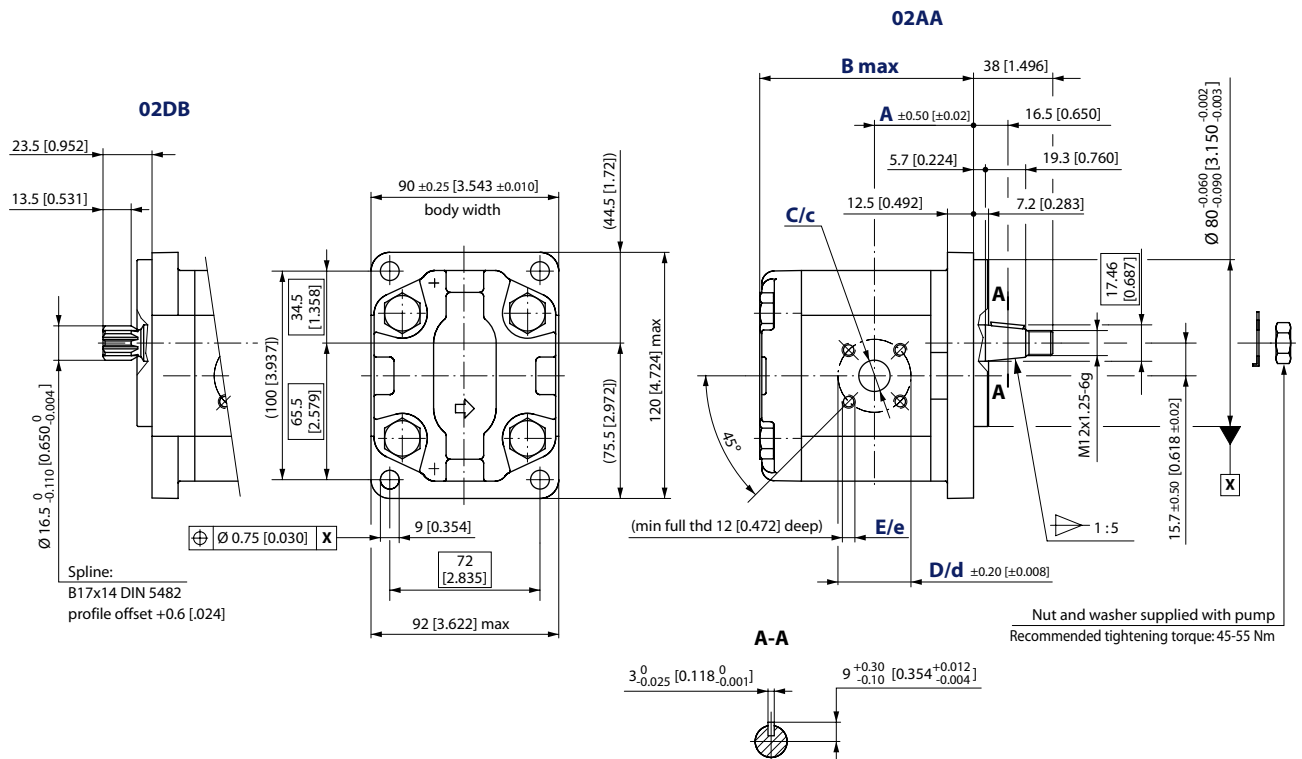

*SNP2NN – 02DB and 02AA dimensions*

Frame size	4,0	6,0	8,0	011	014	017	019	022	025	
Dimension	A	39.8 [1.567]	41.1 [1.618]	43.1 [1.697]	47.5 [1.870]	47.5 [1.870]	47.5 [1.870]	47.5 [1.870]	55 [2.165]	64.5 [2.539]
	B	92.5 [3.642]	96 [3.780]	100 [3.937]	104 [4.094]	110 [4.331]	114 [4.488]	118 [4.646]	124 [4.882]	128 [5.039]
Inlet	C	15 [0.591]		20 [0.787]						
	D	40 [1.575]								
	E	M6								
Outlet	c	15 [0.591]								
	d	35 [1.378]								
	e	M6								

*Model code examples and maximum shaft torque*

Flange/drive gear	Model code example	Maximum shaft torque
02DB	SNP2NN/017LN02DBP1B7B5NNNN/NNNNN	130 N•m [1151 lb•in]
02AA	SNP2NN/6,0RN02AAP1B6B5NNNN/NNNNN	140 N•m [1239 lb•in]

For further details on ordering, see *Model Code*, pages 8÷11.

### Gear pump dimensions (continued)

### SNP2NN – 03CA

This drawing shows the standard porting for 03CA.

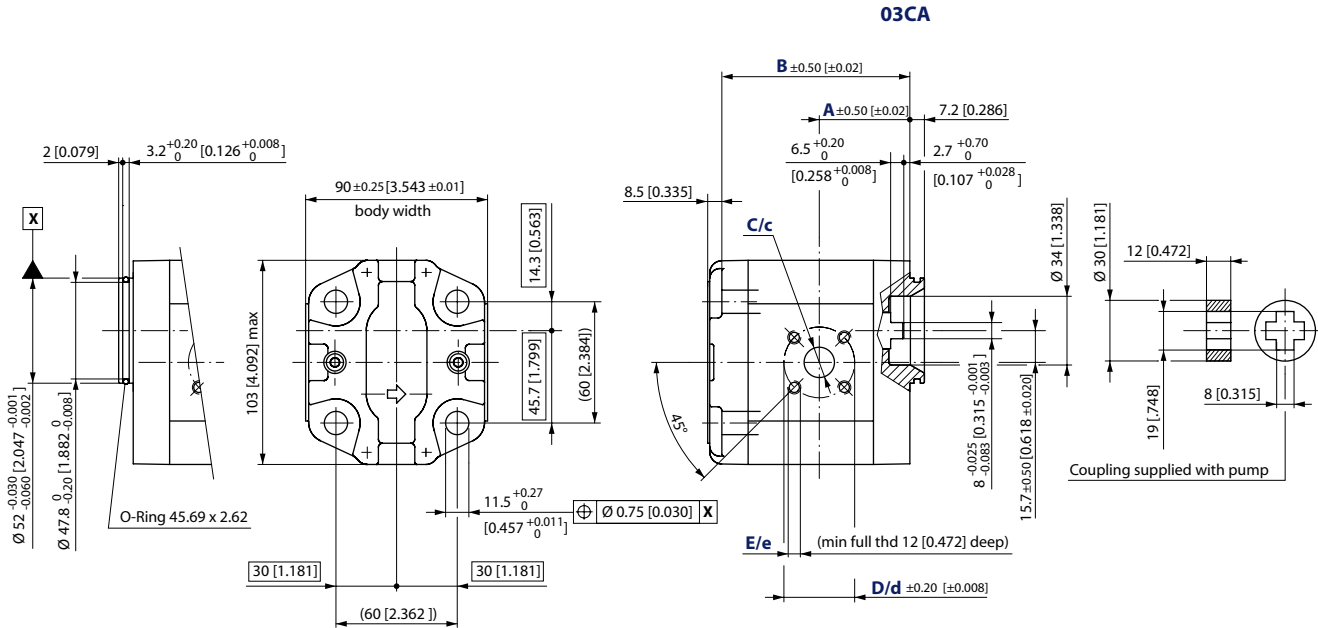

### SNP2NN – 03CA dimensions

Frame size		4,0	6,0	8,0	011	014	017	019	022	025
Dimension	<b>A</b>	37.3 [1.469]	38.6 [1.520]	40.6 [1.598]	45 [1.772]	45 [1.772]	45 [1.772]	45 [1.772]	52.5 [2.067]	62 [2.441]
	<b>B</b>	81.5 [3.209]	85 [3.346]	89 [3.504]	93 [3.661]	99 [3.897]	103 [4.055]	107 [4.212]	113 [4.448]	117 [4.606]
Inlet	<b>C</b>	15 [0.591]			20 [0.787]					
	<b>D</b>	40 [1.575]								
	<b>E</b>	M6								
Outlet	<b>c</b>	15 [0.591]								
	<b>d</b>	35 [1.378]								
	<b>e</b>	M6								

### Model code example and maximum shaft torque

Flange/drive gear	Model code example	Maximum shaft torque
<b>03CA</b>	SNP2NN/014RN03CAP3B7B5NNNN/NNNN	70 N·m [620 lb·in]

For further details on ordering, see *Model Code*, pages 8÷11.



**Gear pump dimensions (continued)**

**SNP2NN – 04/05DB and 04/05AA**

This drawing shows the standard porting for 04/05AA and 04/05DB.

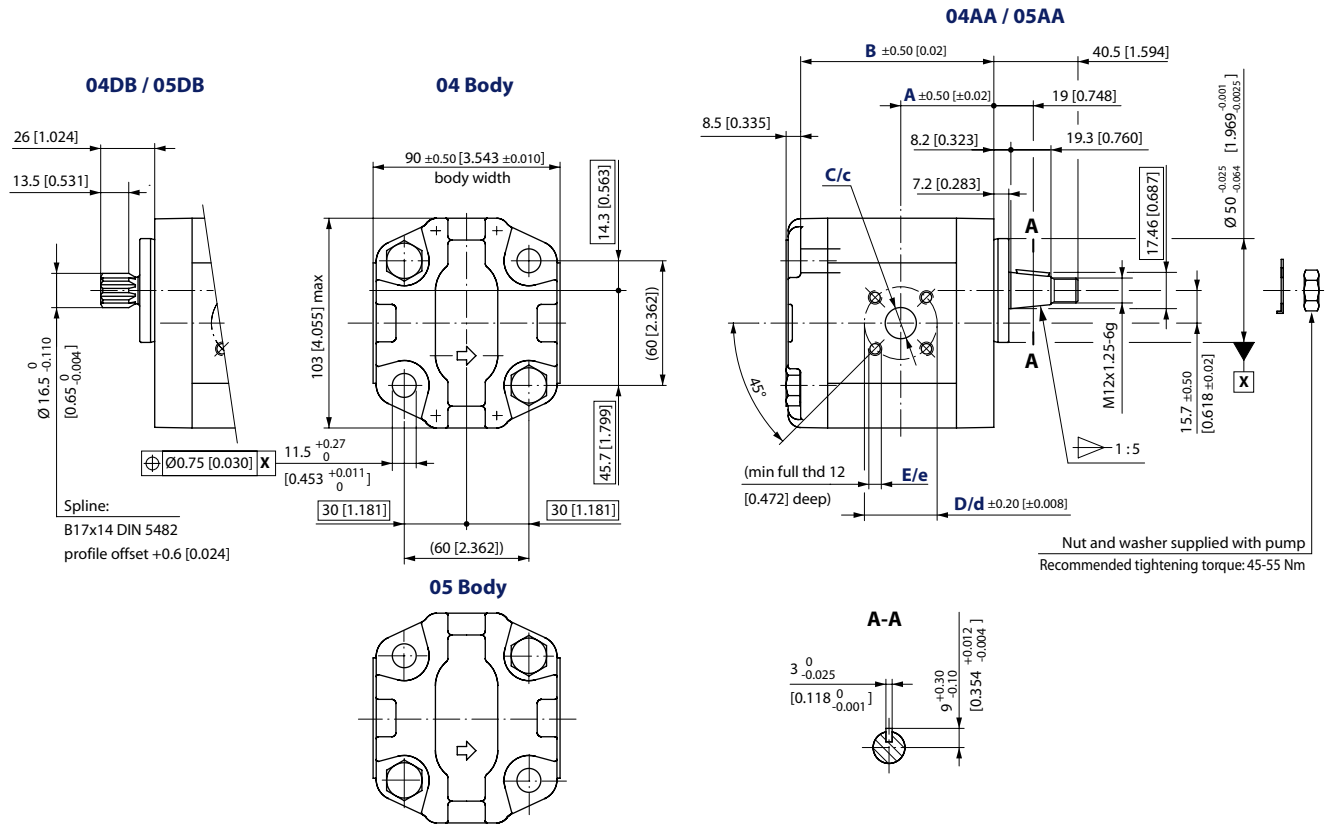

*SNP2NN – 04/05DB and 04/05AA dimensions*

Frame size	4,0	6,0	8,0	011	014	017	019	022	025
Dimension	<b>A</b>	37.3 [1.469]	38.6 [1.520]	40.6 [1.598]	45 [1.772]	45 [1.772]	45 [1.772]	52.5 [2.067]	62 [2.441]
	<b>B</b>	81.5 [3.208]	85 [3.364]	89 [3.503]	93 [3.661]	99 [3.897]	103 [4.055]	107 [4.212]	113 [4.448]
Inlet	<b>C</b>	15 [0.591]		20 [0.787]					
	<b>D</b>	40 [1.575]							
	<b>E</b>	M6							
Outlet	<b>c</b>	15 [0.591]							
	<b>d</b>	35 [1.378]							
	<b>e</b>	M6							

*Model code examples and maximum shaft torque*

Flange/drive gear	Model code example	Maximum shaft torque
<b>04DB</b>	SNP2NN/8,0LN04DBP1B7B5NNNN/NNNNN	130 N·m [1151 lb·in]
<b>05DB</b>	SNP2NN/022RN05DBP1B7B5NNNN/NNNNN	
<b>04AA</b>	SNP2NN/6,0LN04AAP1B6B5NNNN/NNNNN	140 N·m [1239 lb·in]
<b>05AA</b>	SNP2NN/014RN05AAP1B7B5NNNN/NNNNN	

For further details on ordering, see *Model Code*, pages 8÷11.

### Gear pump dimensions (continued)

### SKP2NN – 06SB and SNP2NN – 06SA, 06GA

This drawing shows the standard porting for 06SB, 06GA and 06SA.

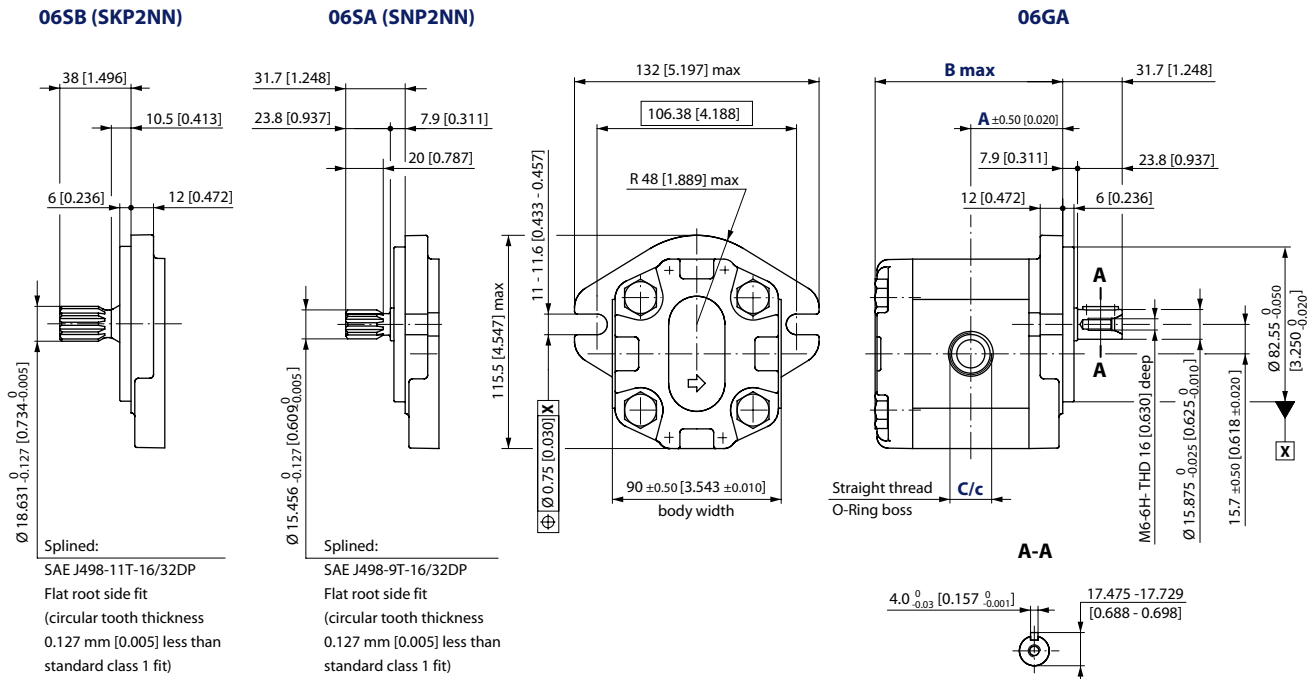

### SNP2NN – 06SA, 06GA and SKP2NN – 06SB dimensions

Frame size	4,0	6,0	8,0	011	014	017	019	022	025	
Dimension	A	43.25 [1.703]	45 [1.772]	47 [1.850]	49 [1.920]	52 [2.047]	54 [2.205]	56 [2.205]	59 [2.323]	61 [2.402]
	B	90 [3.543]	93.5 [3.681]	97.5 [3.839]	101.5 [3.996]	107.5 [4.232]	111.5 [4.390]	115.5 [4.547]	121.5 [4.783]	125.5 [4.941]
Inlet	C	1 <sup>1</sup> / <sub>16</sub> -12UNF-2B, 18.0 [0.709] deep								
Outlet	c	7 <sup>1</sup> / <sub>8</sub> -14UNF-2B, 16.7 [0.658] deep								

### Model code examples and maximum shaft torque

Flange/drive gear	Model code example	Maximum shaft torque
<b>06GA</b>	SNP2NN/6,0RN06GAP1E6E5NNNNN/NNNNN	80 N·m [708 lb·in]
<b>06SA (SNP2NN)</b>	SNP2NN/011LN06SAP1E6E5NNNNN/NNNNN	75 N·m [664 lb·in]
<b>06SB (SKP2NN)</b>	SKP2NN/022RN06SBP1E6E5NNNNN/NNNNN	150 N·m [1328 lb·in]

For further details on ordering, see *Model Code*, pages 8÷11.

**Gear pump dimensions  
(continued)**

**SNP2NN – 06SA..BxBxYY../.....**

This drawing shows the standard porting for 06SA with port type Bx offset from center of the body.

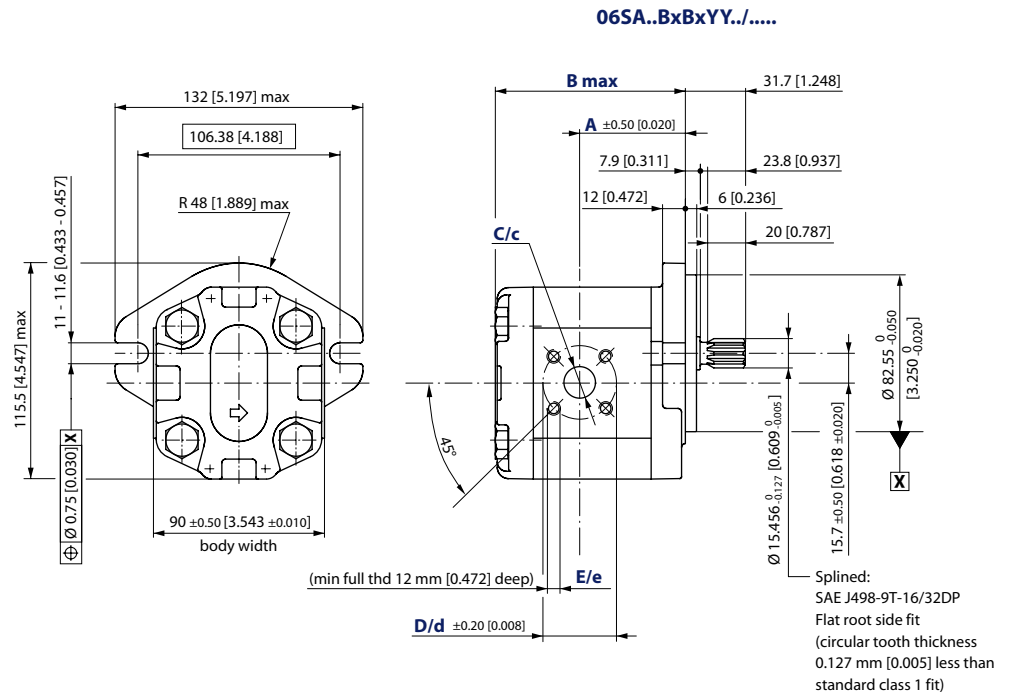

*SNP2NN – 06SA..BxBxYY../..... dimensions*

Frame size	4,0	6,0	8,0	011	014	017	019	022	025	
Dimension	<b>A</b>	49.2 [1.937]	51.4 [2.023]	53.4 [2.102]	53 [2.087]	59 [2.322]	63 [2.480]	67 [2.637]	65.5 [2.579]	60 [2.326]
	<b>B</b>	90 [3.543]	93.5 [3.681]	97.5 [3.839]	101.5 [3.996]	107.5 [4.232]	111.5 [4.390]	115.5 [4.547]	121.5 [4.783]	125.5 [4.941]
Inlet	<b>C</b>	15 [0.591]			20 [0.787]					
	<b>D</b>	40 [1.575]								
	<b>E</b>	M6								
Outlet	<b>c</b>	15 [0.591]								
	<b>d</b>	35 [1.378]								
	<b>e</b>	M6								

*Model code examples and maximum shaft torque*

Flange/drive gear	Model code example	Maximum shaft torque
06SA..BxBxYY../.....	SNP2NN/019RN06SAP1B7B5YYNN/NNNNN	75 N·m [646 lb·in]

For further details on ordering, see *Model Code*, pages 8÷11.

### Gear pump dimensions (continued)

### SNP2NN – 09BJ

This drawing shows the standard porting for 09BJ.

#### 09BJ

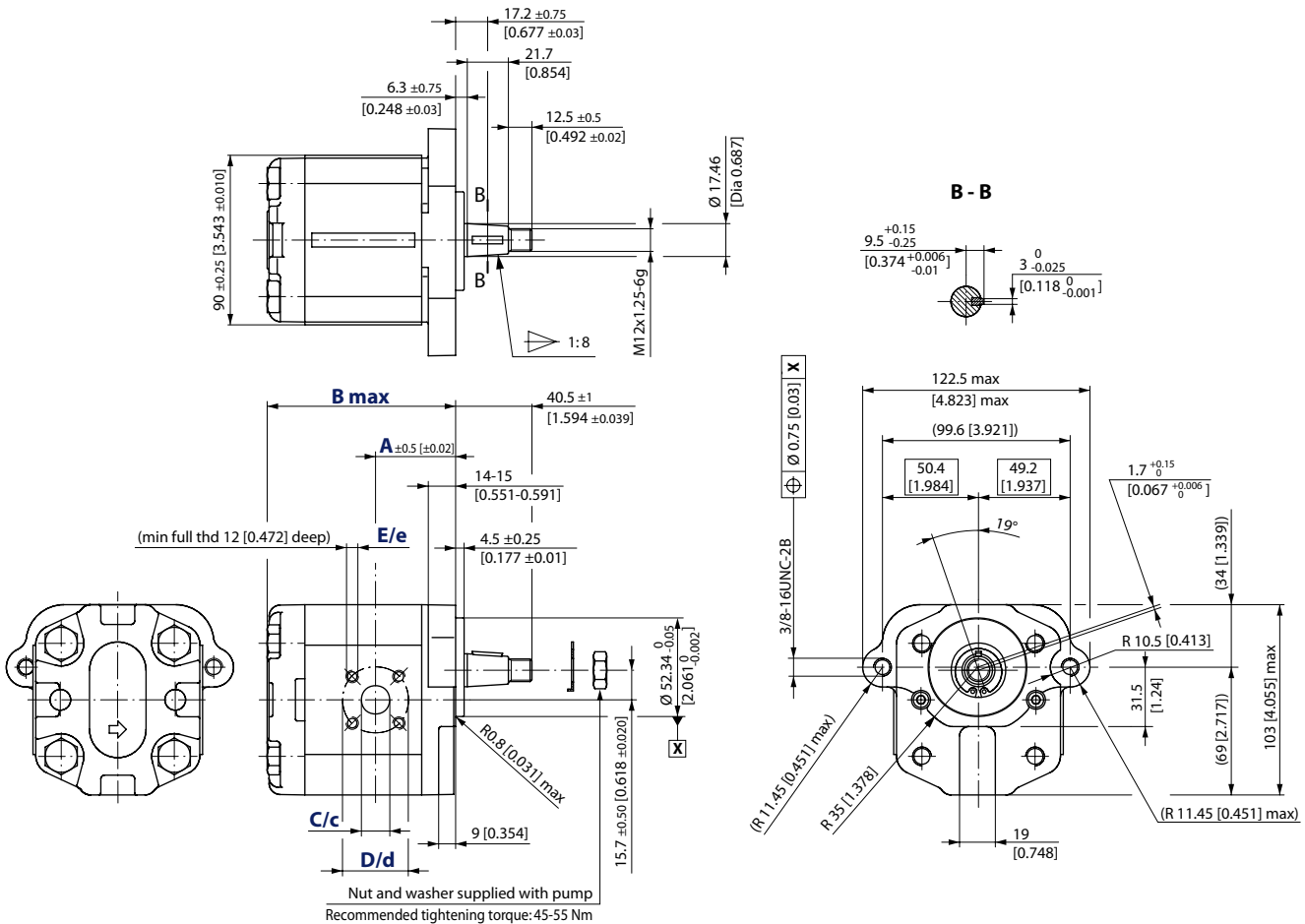

### SNP2NN – 09BJ dimensions

Frame size		4,0	6,0	8,0	011	014	017	019	022	025
Dimension	A	37.3 [1.469]	38.6 [1.52]	40.6 [1.598]	45 [1.772]				52.5 [2.067]	62 [2.44]
	B	90 [3.543]	93.5 [3.68]	97.5 [3.839]	101.5 [3.996]	107.5 [4.232]	111.5 [4.390]	115.5 [4.547]	121.5 [4.783]	125.5 [4.94]
Inlet	C	15 [0.591]		20 [0.787]						
	D	40 [1.575]								
	E	M6								
Outlet	c	15 [0.591]								
	d	35 [1.378]								
	e	M6								

### Model code example and maximum shaft torque

Flange/drive gear	Model code example	Maximum shaft torque
09BJ	SNP2NN/014LN09BJP1B7B5NNNN/NNNN	150 N·m [1328 lb·in]

For further details on ordering, see *Model Code*, pages 8÷11.

**Gear pump dimensions  
(continued)**

**SNP2NN – A9BJ**

This drawing shows the standard porting for A9BJ.

**A9BJ**

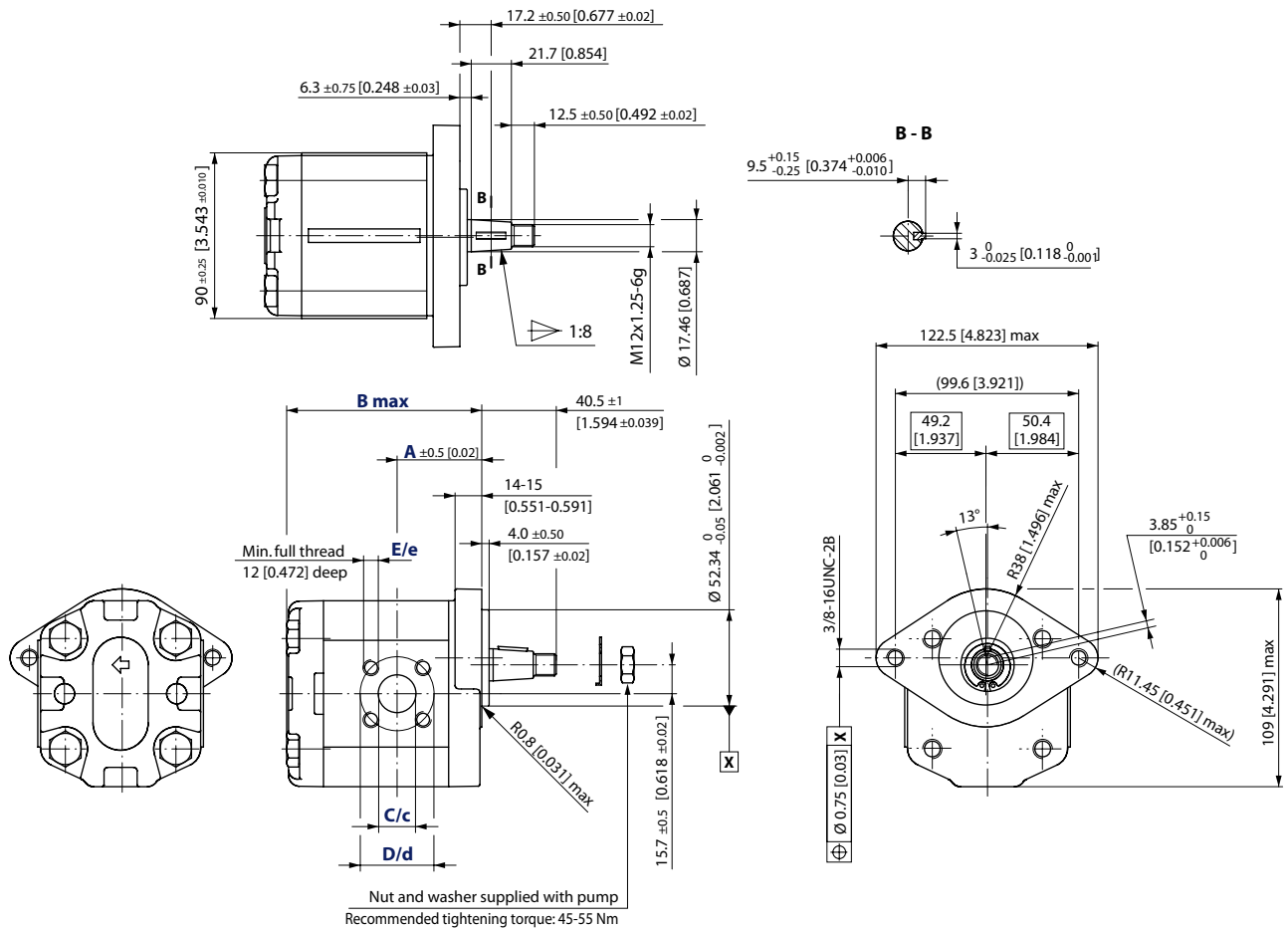

*SNP2NN – A9BJ dimensions*

Frame size		4,0	6,0	8,0	011	014	017	019	022	025
Dimension	<b>A</b>	37.3 [1.469]	38.6 [1.52]	40.6 [1.598]	45 [1.772]				52.5 [2.067]	62 [2.44]
	<b>B</b>	90 [3.543]	93.5 [3.68]	97.5 [3.839]	101.5 [3.996]	107.5 [4.232]	111.5 [4.390]	115.5 [4.547]	121.5 [4.783]	125.5 [4.94]
Inlet	<b>C</b>	15 [0.591]		20 [0.787]						
	<b>D</b>	40 [1.575]								
	<b>E</b>	M6								
Outlet	<b>c</b>	15 [0.591]								
	<b>d</b>	35 [1.378]								
	<b>e</b>	M6								

*Model code example and maximum shaft torque*

Flange/drive gear	Model code example	Maximum shaft torque
<b>A9BJ</b>	SNP2NN/014LNA9BJP1B7B5NNNN/NNNN	150 N•m [1328 lb•in]

For further details on ordering, see *Model Code*, pages 8÷11.

### Gear motor dimensions SNM2NN – 01DA, 01FA and 01BA

This drawing shows the standard porting for 01DA, 01FA and 01BA.

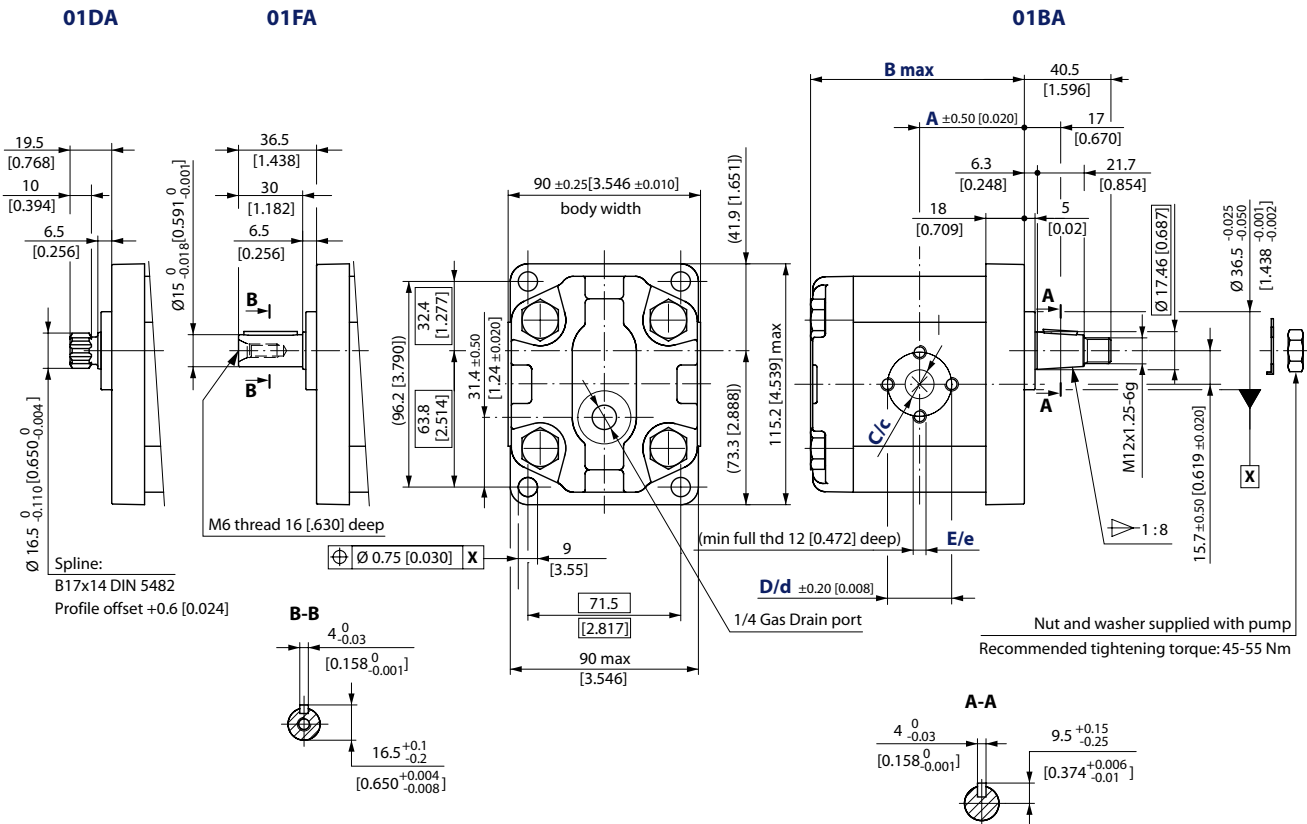

### SNM2NN – 01DA, 01FA and 01BA dimensions

Frame size	6,0	8,0	011	014	017	019	022	025
Dimension	<b>A</b>	45 [1.771]	49 [1.929]	52 [2.047]	56 [2.204]	59 [2.322]		
	<b>B</b>	93.5 [3.681]	97.5 [3.838]	101.5 [3.996]	107.5 [4.232]	111.5 [4.389]	121.5 [4.783]	125.5 [4.940]
Inlet/Outlet	<b>C/c</b>	13.5 [0.531]		20 [0.787]		23.5 [0.925]		
	<b>D/d</b>	30 [1.181]		40 [1.575]				
	<b>E/e</b>	M6		M8				

### Model code examples and maximum shaft torque

Flange/drive gear configuration	Model code example	Maximum shaft torque [lb·in]
<b>01DA</b>	SNM2NN/8,0BN01DAM1C3C3NNNN/NNNNN	90 N·m [797 lb·in]
<b>01FA</b>	SNM2NN/022BN01FAM1C7C7NNNN/NNNNN	90 N·m [797 lb·in]
<b>01BA</b>	SNM2NN/017BN01BAM1C7C7NNNN/NNNNN	150 N·m [1328 lb·in]

For further details on ordering, see *Model Code*, pages 8÷11.

**Gear motor dimensions (continued)**

**SNM2NN – 02DB and 02AA**

This drawing shows the standard porting for 02AA and 02DB.

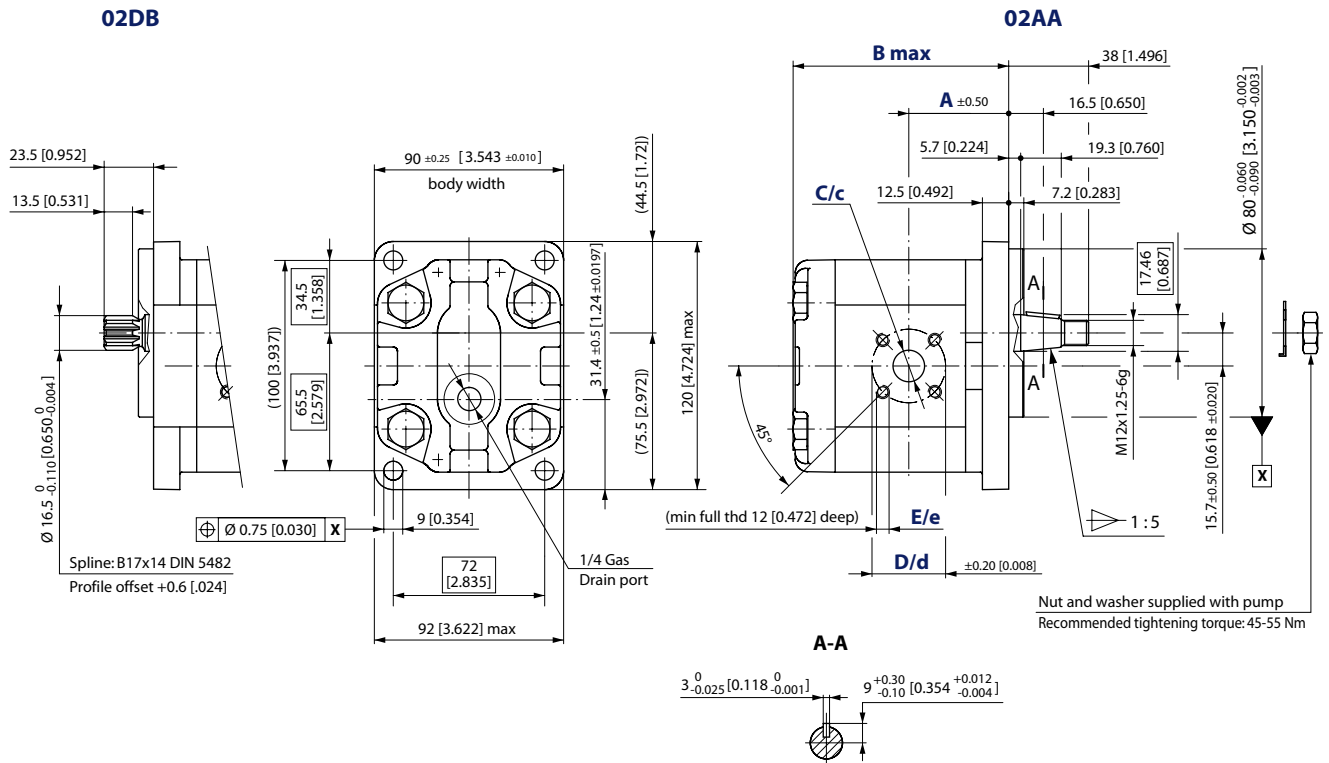

*SNM2NN – 02DB and 02AA dimensions*

Frame size	6,0	8,0	011	014	017	019	022	025	
Dimension	<b>A</b>	41.1 [1.618]	43.1 [1.697]	47.5 [1.870]	47.5 [1.870]	47.5 [1.870]	47.5 [1.870]	55 [2.165]	64.5 [2.539]
	<b>B</b>	96 [3.780]	100 [3.937]	104 [4.094]	110 [4.331]	114 [4.488]	118 [4.646]	124 [4.882]	128 [5.039]
Inlet/Outlet	<b>C/c</b>	15 [0.591]					20 [0.787]		
	<b>D/d</b>	35 [1.378]					40 [1.575]		
	<b>E/e</b>	M6							

*Model code examples and maximum shaft torque*

Flange/drive gear	Model code example	Maximum shaft torque
<b>02DB</b>	SNM2NN/025BN02DBM1B7B7NNNN/NNNNN	90 N•m [797 lb•in]
<b>02AA</b>	SNM2NN/8,0BN02AAM1B5B5NNNN/NNNNN	140 N•m [1239 lb•in]

For further details on ordering, see *Model Code*, pages 8÷11.





**Gear motor dimensions (continued)**

**SNM2NN – 04/05DB and 04/05AA**

This drawing shows the standard porting for 04/05DB, 04/05AA.

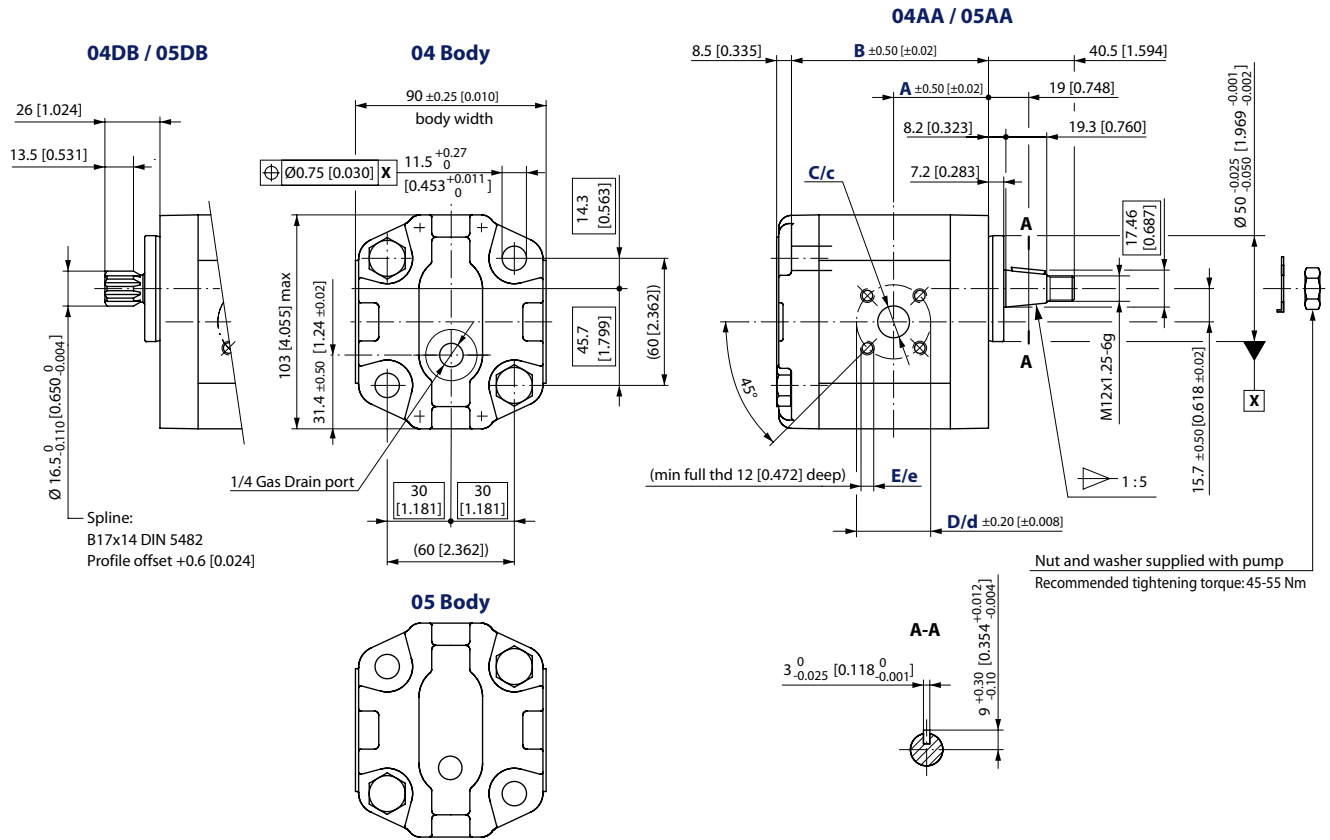

*SNM2NN – 04/05DB and 04/05AA dimensions*

Frame size	6,0	8,0	011	014	017	019	022	025	
Dimension	A	38.6 [1.520]	40.6 [1.598]	45 [1.772]			52.5 [2.067]	62 [2.441]	
	B	85 [3.364]	89 [3.503]	93 [3.661]	99 [3.897]	103 [4.055]	107 [4.212]	113 [4.448]	117 [4.606]
Inlet/Outlet	C/c	15 [0.591]					20 [0.787]		
	D/d	35 [1.378]					40 [1.575]		
	E/e	M6							

*Model code examples and maximum shaft torque*

Flange/drive gear	Model code example	Maximum shaft torque
04DB	SNM2NN/8,0BN04DBAM1B5B5NNNN/NNNNN	130 N•m [1151 lb•in]
05DB	SNM2NN/017BN05DBM1B5B5NNNN/NNNNN	
04AA	SNM2NN/8,0BN04AAM1B5B5NNNN/NNNNN	140 N•m [1239 lb•in]
05AA	SNM2NN/017BN05AAM1B5B5NNNN/NNNNN	

For further details on ordering, see *Model Code*, pages 8÷11.

### Gear motor dimensions (continued)

### SNM2NN – 06SA and 06GA

This drawing shows the standard porting for 06SA and 06GA.

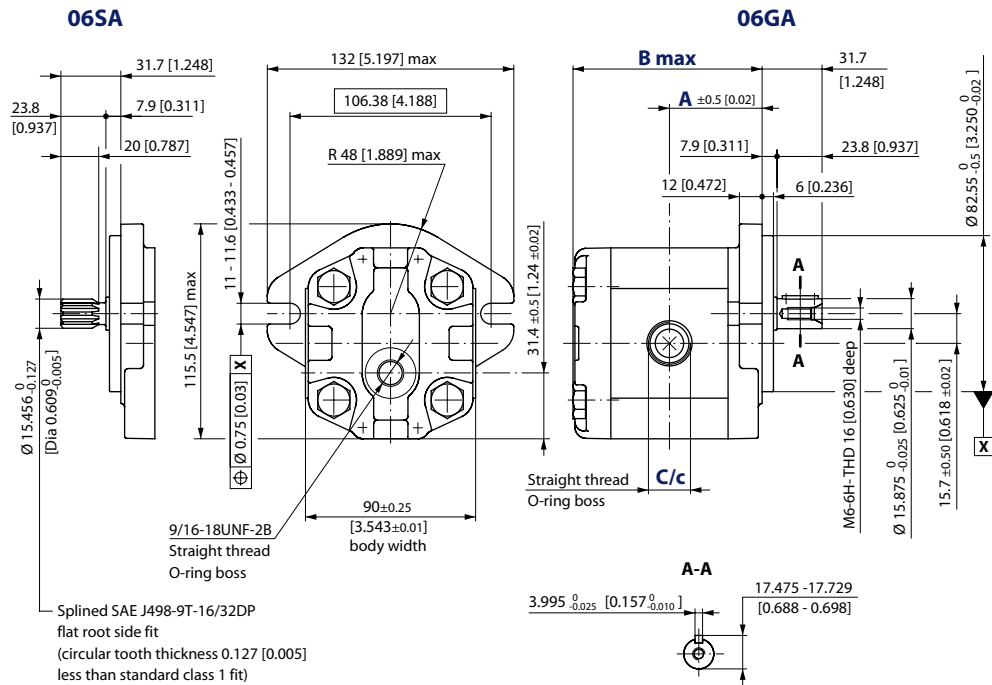

### SNM2NN – 06SA and 06GA dimensions

Frame size		6,0	8,0	011	014	017	019	022	025
Dimension	A	45 [1.772]	47 [1.85]	49 [1.92]	52 [2.047]	54 [2.205]	56 [2.205]	59 [2.323]	61 [2.402]
	B	93.5 [3.681]	97.5 [3.839]	101.5 [3.996]	107.5 [4.232]	111.5 [4.390]	115.5 [4.547]	121.5 [4.783]	125.5 [4.941]
Inlet/Outlet	C/c	7/8-14UNF-2B, 16.7 [0.658] deep					1 1/16-12UNF-2B, 18 [0.709] deep		

### Model code examples and maximum shaft torque

Flange/drive gear	Model code example	Maximum shaft torque
<b>06SA</b>	SNM2NN/8,0BN06SAM1E5E5NNNN/NNNNN	75 N•m [664 lb•in]
<b>06GA</b>	SNM2NN/017BN06GAM6E5E5NNNN/NNNNN	80 N•m [708 lb•in]

For further details on ordering, see [Model Code](#), pages 8÷11.

Group 2 pump ports

Available pump ports for Group 2

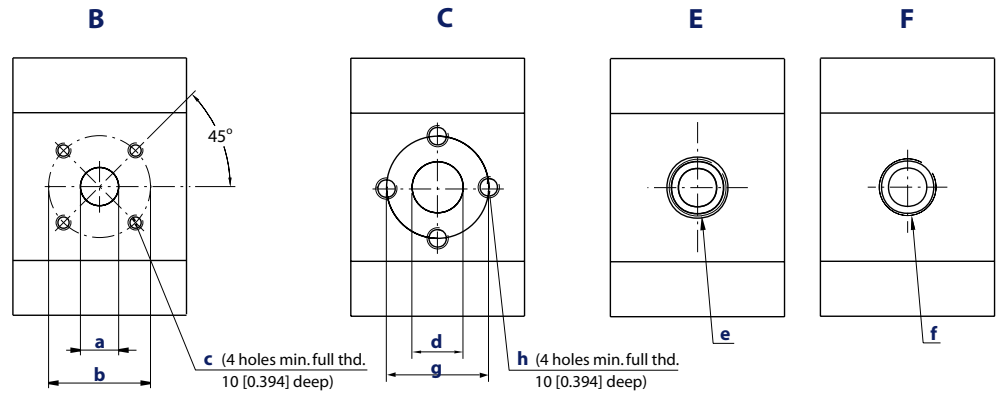

Dimensions of Group 2 pumps ports

Port type		B			C			E	F	
Port dimensions		a	b	c	d	g	h	e	f	
Frame size	4,0	Inlet	15 [0.591]	40 [1.575]	M6	13.5 [0.531]	30 [1.181]	M6	1 1/16-12UNF-2B	1/2 Gas (BSPP)
		Outlet	15 [0.591]	35 [1.378]	M6	13.5 [0.531]	30 [1.181]	M6	7/8-14UNF-2B	1/2 Gas (BSPP)
	6,0	Inlet	15 [0.591]	40 [1.575]	M6	13.5 [0.531]	30 [1.181]	M6	1 1/16-12UNF-2B	1/2 Gas (BSPP)
		Outlet	15 [0.591]	35 [1.378]	M6	13.5 [0.531]	30 [1.181]	M6	7/8-14UNF-2B	1/2 Gas (BSPP)
	8,0	Inlet	20 [0.787]	40 [1.575]	M6	13.5 [0.531]	30 [1.181]	M6	1 1/16-12UNF-2B	1/2 Gas (BSPP)
		Outlet	15 [0.591]	35 [1.378]	M6	13.5 [0.531]	30 [1.181]	M6	7/8-14UNF-2B	1/2 Gas (BSPP)
	011	Inlet	20 [0.787]	40 [1.575]	M6	13.5 [0.531]	30 [1.181]	M6	1 1/16-12UNF-2B	3/4 Gas (BSPP)
		Outlet	15 [0.591]	35 [1.378]	M6	13.5 [0.531]	30 [1.181]	M6	7/8-14UNF-2B	1/2 Gas (BSPP)
	014	Inlet	20 [0.787]	40 [1.575]	M6	20.0 [0.787]	40 [1.575]	M6	1 1/16-12UNF-2B	3/4 Gas (BSPP)
		Outlet	15 [0.591]	35 [1.378]	M6	13.5 [0.531]	30 [1.181]	M6	7/8-14UNF-2B	1/2 Gas (BSPP)
	017	Inlet	20 [0.787]	40 [1.575]	M6	20.0 [0.787]	40 [1.575]	M6	1 1/16-12UNF-2B	3/4 Gas (BSPP)
		Outlet	15 [0.591]	35 [1.378]	M6	13.5 [0.531]	30 [1.181]	M6	7/8-14UNF-2B	1/2 Gas (BSPP)
	019	Inlet	20 [0.787]	40 [1.575]	M6	20.0 [0.787]	40 [1.575]	M6	1 1/16-12UNF-2B	3/4 Gas (BSPP)
		Outlet	15 [0.591]	35 [1.378]	M6	13.5 [0.531]	30 [1.181]	M6	7/8-14UNF-2B	1/2 Gas (BSPP)
	022	Inlet	20 [0.787]	40 [1.575]	M6	20.0 [0.787]	40 [1.575]	M6	1 1/16-12UNF-2B	3/4 Gas (BSPP)
		Outlet	15 [0.591]	35 [1.378]	M6	13.5 [0.531]	30 [1.181]	M6	7/8-14UNF-2B	1/2 Gas (BSPP)
025	Inlet	20 [0.787]	40 [1.575]	M6	23.5 [0.925]	40 [1.575]	M8	1 1/16-12UNF-2B	1 Gas (BSPP)	
	Outlet	15 [0.591]	35 [1.378]	M6	20.0 [0.787]	40 [1.575]	M8	7/8-14UNF-2B	3/4 Gas (BSPP)	

### Group 2 motor ports

Available motor ports for Group 2

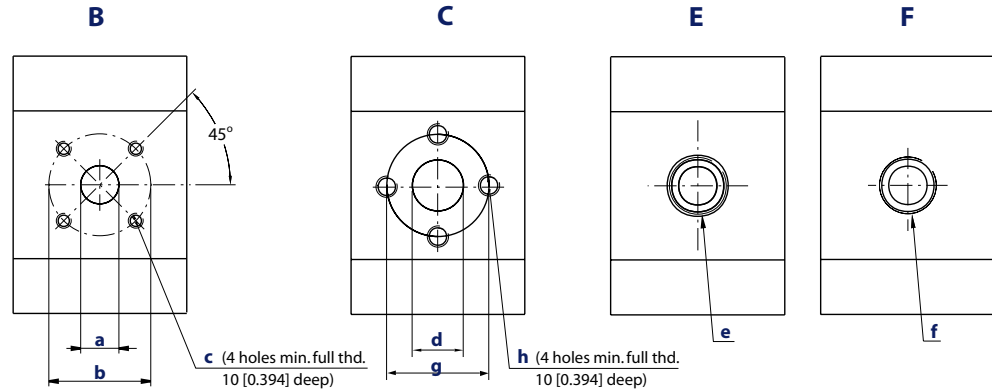

### Dimensions of Group 2 motors ports

Port type		B			C			E	F	
Port dimensions		a	b	c	g	d	h	e	f	
Frame size	<b>6,0</b>	Inlet/Outlet	15 [0.591]	35 [1.378]	M6	30 [1.181]	13.5 [0.531]	M6	7/8-14UNF-2B	1/2 Gas (BSPP)
	<b>8,0</b>	Inlet/Outlet	15 [0.591]	35 [1.378]	M6	30 [1.181]	13.5 [0.531]	M6	7/8-14UNF-2B	1/2 Gas (BSPP)
	<b>011</b>	Inlet/Outlet	15 [0.591]	35 [1.378]	M6	30 [1.181]	13.5 [0.531]	M6	7/8-14UNF-2B	1/2 Gas (BSPP)
	<b>014</b>	Inlet/Outlet	15 [0.591]	35 [1.378]	M6	40 [1.575]	20.0 [0.787]	M8	7/8-14UNF-2B	1/2 Gas (BSPP)
	<b>017</b>	Inlet/Outlet	15 [0.591]	35 [1.378]	M6	40 [1.575]	20.0 [0.787]	M8	7/8-14UNF-2B	1/2 Gas (BSPP)
	<b>019</b>	Inlet/Outlet	20 [0.787]	40 [1.575]	M6	40 [1.575]	20.0 [0.787]	M8	1 1/16-12UNF-2B	3/4 Gas (BSPP)
	<b>022</b>	Inlet/Outlet	20 [0.787]	40 [1.575]	M6	40 [1.575]	20.0 [0.787]	M8	1 1/16-12UNF-2B	3/4 Gas (BSPP)
	<b>025</b>	Inlet/Outlet	20 [0.787]	40 [1.575]	M6	40 [1.575]	23.5 [0.925]	M8	1 1/16-12UNF-2B	3/4 Gas (BSPP)
<b>Drain</b>					1/4 Gas (BSPP)			3/16-18UNF-2B	1/4 Gas (BSPP)	

#### Shaft options

Group 2 pumps are available with a variety of splined, parallel, and tapered shaft ends. Not all shaft styles are available with all flange styles.

Valid combinations and nominal torque ratings are shown in the table below. Torque ratings assume no external radial loading. Applied torque must not exceed these limits regardless of pressure parameters stated earlier. Maximum torque ratings are based on shaft torsional fatigue strength.

Recommended mating splines for Group 2 splined output shafts should be in accordance with SAE J498 or DIN 5482. TurollaOCG external SAE splines are flat root side fit with circular tooth thickness reduced by 0.127 mm [0.005 in] in respect to class 1 fit. The external DIN splines have an offset increased by 0.1 mm [0.004 in.] These dimensions are modified in order to assure a clearance fit with the mating spline.

Other shaft options may exist. Contact your TurollaOCG representative for availability.

#### Shaft and flange availability

#### Shaft and flange availability and torque capability

This table details the standard Group 2 shafts and flange combinations that are currently available with the maximum shaft torque limits. For further information, please see TurollaOCG publications *Group 2 Gear Pumps Technical Information, L1016341* and *Group 1, 2 and 3 Gear Motors, Technical Information, L1016082*.

#### Shaft and flange availability and torque capability

Shaft Description	Code	Mounting flange code with maximum torque in N•m [lb•in]							
		01	02	03	04	05	06	09	0B
Taper 1:5	AA	–	140 [1239]	–	140 [1239]	140 [1239]	–	–	–
Taper 1:8	BA	150 [1328]	–	–	–	–	–	150 [1328]	150 [1328]
DIN spline 9T, B17x14	DA	90 [797]	–	–	–	–	–	–	–
DIN spline 9T, B17x14	DB	–	130 [1151]	–	130 [1151]	130 [1151]	–	–	–
SAE spline 9T, 16/32p	SA	–	–	–	–	–	75 [646]	–	–
SAE spline 11T, 16/32p	SB	–	–	–	–	–	150 [1328]	–	–
Parallel 15 mm [0.590 in]	FA	90 [797]	–	–	–	–	–	–	–
Parallel 15.875 mm [0.625 in]	GA	–	–	–	–	–	80 [708]	–	–
TurollaOCG Tang	CA	–	–	70 [620]	–	–	–	–	–

## General Aluminum Gear Pumps and Motors Technical Information Group 3

### Overview

TuroliaOCG' Group 3 Series of gear pumps and motors uses an external spur gear, and positive displacement design pump of proven high pressure and efficiency. Constructed of three-piece aluminum body, it has been repeatedly proven, with many years experience in hydraulic products for mobile and industrial applications.

The extruded aluminum housing provides the necessary strength construction while providing a very high power to weight ratio and increased heat dissipation. Its aluminum housing permits the gear teeth to cut in toward the inlet side and create their own path for maximum radial gear tip seal and high volumetric efficiency.

The Group 3 Series is composed of the SNP3NN gear pump and two motors, the bi-directional SNM3NN and uni-directional SNU3NN. They look like this:

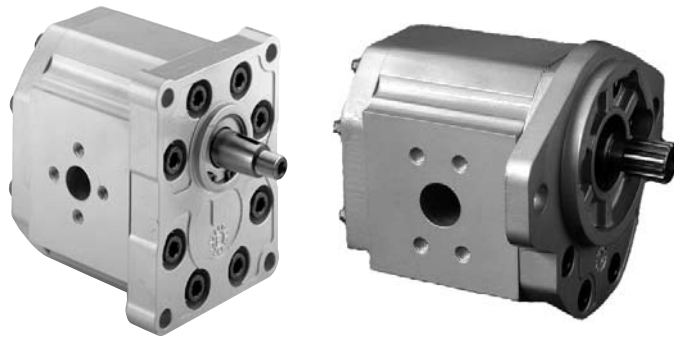

### Design

Super finished shaft journals, floating pressure plates, and Teflon coated large DU bearings are protected by an extruded aluminum alloy gear housing. The one-piece shaft is set within a high-strength aluminum flange and cover, open to numerous options, including,



### Features

Special features within Group 3 family include:

- wide range of displacements (from 22 to 90 cm<sup>3</sup>/rev [1.34 to 5.49 in<sup>3</sup>/rev] for pumps and motors)
- SAE, DIN, and European standard mounting flanges
- high quality case hardened steel gears
- pressure plates that provide efficiency at all speeds
- contact force between bearing face and gear is low and precisely controlled
- volumetric efficiencies in the range of 95%
- multiple pump configurations in combination with SNP1NN, SNP2NN and SNP3NN.

## Technical data for pumps

### Technical data for SNP3NN

Frame size		022	026	033	038	044	048	055	063	075	090
Displacement	cm <sup>3</sup> /rev [in <sup>3</sup> /rev]	22.1 [1.35]	26.2 [1.60]	33.1 [2.02]	37.9 [2.32]	44.1 [2.69]	48.3 [2.93]	55.1 [3.36]	63.4 [3.87]	74.4 [4.54]	88.2 [5.38]
Peak pressure	bar [psi]	270 [3910]	270 [3910]	270 [3910]	270 [3910]	270 [3910]	250 [3625]	250 [3625]	230 [3350]	200 [2910]	170 [2465]
Rated pressure		250 [3625]	250 [3625]	250 [3625]	250 [3625]	250 [3625]	230 [3336]	230 [3336]	210 [3045]	180 [2610]	150 [2175]
Minimum speed	min <sup>-1</sup> (rpm)	800	800	800	800	800	800	800	600	600	600
Maximum speed		3000	3000	3000	3000	3000	3000	2500	2500	2500	2500
Weight	kg [lb]	6.8 [15.0]	6.8 [15.0]	7.2 [15.8]	7.3 [16.1]	7.5 [16.5]	7.6 [16.8]	7.8 [17.3]	8.1 [17.9]	8.5 [18.7]	8.9 [19.6]
Moment of inertia of rotating components	x 10 <sup>-6</sup> kg·m <sup>2</sup> [x 10 <sup>-6</sup> lbf·ft <sup>2</sup> ]	198 [4698]	216 [5126]	246 [5838]	267,2 [6340]	294,2 [6891]	312,2 [7408]	342,3 [8123]	378,3 [8977]	426,4 [10118]	486,5 [11545]
Theoretical flow at maximum speed	l/min [US gal/min]	66.3 [17.5]	78.6 [20.8]	99.3 [26.2]	113.7 [30.0]	132.3 [35.0]	144.9 [38.3]	137.8 [36.4]	158.5 [41.8]	186 [49.1]	220.5 [58.3]

1 kg·m<sup>2</sup> = 23.68 lb·ft<sup>2</sup>

### Technical data for SEP3NN

Frame size		022	026	033	038	044
Displacement	cm <sup>3</sup> /rev [in <sup>3</sup> /rev]	22.1 [1.35]	26.2 [1.60]	33.1 [2.02]	37.9 [2.32]	44.1 [2.69]
Peak pressure	bar [psi]	230 [3336]	230 [3336]	230 [3336]	230 [3336]	200 [2910]
Rated pressure		210 [3045]	210 [3045]	210 [3045]	210 [3045]	180 [2610]
Minimum speed	min <sup>-1</sup> (rpm)	1000	1000	1000	1000	800
Maximum speed		3000	3000	3000	2800	2600
Weight	kg [lb]	5.7 [12.57]	5.8 [12.79]	6.1 [13.45]	6.2 [13.67]	6.4 [14.11]
Moment of inertia of rotating components	x 10 <sup>-6</sup> kg·m <sup>2</sup> [x 10 <sup>-6</sup> lbf·ft <sup>2</sup> ]	198 [4698]	216 [5126]	246 [5873]	294.2 [6981]	312.2 [7408]
Theoretical flow at maximum speed	l/min [US gal/min]	66.3 [17.5]	78.6 [20.8]	99.3 [26.2]	113.7 [30.0]	132.3 [35.0]

These tables detail the technical data for the SNP3NN and SEP3NN gear pumps. The SNP3NN is a standard product. For further information about application and configuration of gear pumps, please see TurollaOCG publication *Group 3 Gear Pumps Technical Information*, **L1016456**.

### ⚠ Caution

The rated and peak pressure mentioned are for pumps with flanged ports only. When threaded ports are required a de-rated performance has to be considered. To verify the compliance of an high pressure application with a threaded ports pump apply to a TurollaOCG representative.

**Technical data for motors**

*Technical data – Group 3 gear motors*

Frame size		022	026	033	038	044	048	055	063	075	090
Displacement	cm <sup>3</sup> /rev	22.1	26.2	33.1	37.9	44.1	48.3	55.2	63.4	74.4	88.2
	[in <sup>3</sup> /rev]	[1.35]	[1.60]	[2.02]	[2.32]	[2.69]	[2.93]	[3.36]	[3.87]	[4.54]	[5.38]
<b>SNU3NN (uni-directional)</b>											
Peak pressure	bar [psi]	270	270	270	270	270	250	230	210	190	170
		[3915]	[3915]	[3915]	[3915]	[3915]	[3625]	[3336]	[3045]	[2755]	[2465]
Rated pressure		250	250	250	250	250	230	210	190	170	150
		[3625]	[3625]	[3625]	[3625]	[3625]	[3336]	[3045]	[2755]	[2465]	[2175]
Minimum speed	min <sup>-1</sup> (rpm)	800	800	800	800	800	800	800	600	600	600
Maximum speed		2500	2500	2500	2500	2300	2300	2300	2300	2100	2100
<b>SNM3NN (bi-directional) motor in parallel</b>											
Peak pressure	bar [psi]	270	270	270	270	270	250	230	210	190	170
		[3915]	[3915]	[3915]	[3915]	[3915]	[3625]	[3335]	[3045]	[2755]	[2465]
Rated pressure		250	250	250	250	250	230	210	190	170	150
		[3625]	[3625]	[3625]	[3625]	[3625]	[3336]	[3045]	[2755]	[2465]	[2175]
Minimum speed	min <sup>-1</sup> (rpm)	800	800	800	800	800	800	800	800	800	800
Maximum speed		2500	2500	2500	2500	2300	2300	2300	2300	2100	2100
<b>SNM3NN (bi-directional) motor in series</b>											
Peak pressure	bar [psi]	250	250	250	250	250	230	210	190	170	150
		[3625]	[3625]	[3625]	[3625]	[3625]	[3336]	[3045]	[2755]	[2465]	[2175]
Rated pressure		250	250	250	250	250	230	210	190	170	150
		[3625]	[3625]	[3625]	[3625]	[3625]	[3336]	[3045]	[2755]	[2465]	[2175]
Minimum speed	min <sup>-1</sup> (rpm)	800	800	800	800	800	800	800	800	800	800
Maximum speed		2500	2500	2500	2500	2300	2300	2200	2100	2100	2100
<b>All (SNU3NN, SNM3NN)</b>											
Weight	kg [lb]	6.8	6.8	7.2	7.3	7.5	7.6	7.8	8.1	8.5	8.9
		[15]	[15]	[15.8]	[16.1]	[16.5]	[16.8]	[17.3]	[17.9]	[18.7]	[19.6]
Moment of inertia of rotating components	x 10 <sup>-6</sup> kg·m <sup>2</sup>	198	216	246	267.2	294.2	312.2	342.3	378.3	426.4	486.5
	[x 10 <sup>-6</sup> lb·ft <sup>2</sup> ]	[4698]	[5126]	[5837]	[6341]	[6981]	[7408]	[8123]	[8977]	[10 118]	[11 545]

1 kg·m<sup>2</sup> = 23.68 lb·ft<sup>2</sup>

This table details the technical data for the SNM3NN and SNU3NN gear motors. For further information about application and configuration of gear motors, please see TurollaOCG publication *Group 1, 2 and 3 Gear Motors, Technical Information, L1016082*.

**ⓘ Caution**

The rated and peak pressure mentioned are for motors with flanged ports only. When threaded ports are required a de-rated performance has to be considered. To verify the compliance of an high pressure application with a threaded ports pump apply to a TurollaOCG representative.



**Gear pump dimensions SNP3NN – 01FA, 01DA, 01BA and SEP3NN – 01BA**

The drawing shows the SNP3NN standard porting for 01FA, 01DA and 01BA.  
The configuration 01BA is available for the SEP3NN and only up to 44cc.

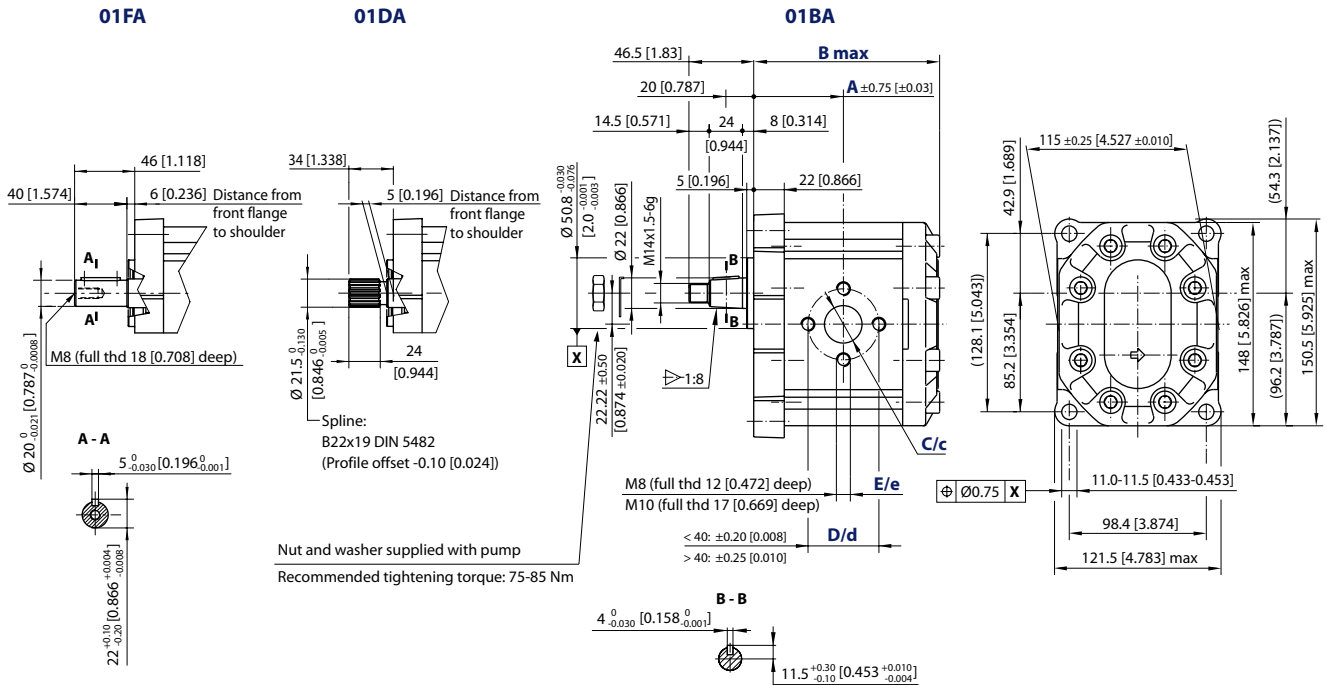

**SNP3NN – 01FA, 01BA, 01DA and SEP3NN – 01BA dimensions**

Frame size	022	026	033	038	044	048	055	063	075	090	
Dimension	A	63 [2.480]	64.5 [2.539]	67 [2.637]	68.8 [2.708]	71 [2.795]	72.5 [2.854]	75 [2.952]	78 [3.07]	82 [3.228]	87 [3.425]
	B	132.5 [5.216]	135.5 [5.334]	140.5 [5.531]	144 [5.669]	148.5 [5.846]	151.5 [5.964]	156.5 [6.161]	162.5 [6.397]	170.5 [6.712]	180.5 [7.106]
Inlet	C	20 [0.787]		27 [1.063]			36 [1.417]				
	D	40 [1.575]		51 [2.007]			62 [2.441]				
	E	M8					M10				
Outlet	c	20 [0.787]			27 [1.063]						
	d	40 [1.575]			51 [2.001]						
	e	M8						M10			

The SEP3NN overall length is 12 mm [0.472 in] less than the SNP3NN for the whole range of displacements (22.1 to 44.1 cm<sup>3</sup>/rev [1.35 to 2.69 in<sup>3</sup>/rev]).

**Model code examples and maximum shaft torque**

Flange/drive gear	Model code example	Maximum shaft torque
01DA	SNP3NN/075LN01DAP1CDCANNNN/NNNNN	290 N•m [2566 lb•in]
01FA	SNP3NN/033RN01FAP1CAC7NNNN/NNNNN	210 N•m [1858 lb•in]
01BA	SNP3NN/022RN01BAP1C7C7NNNN/NNNNN	350 N•m [3097 lb•in]

For further details on ordering, see *Model Code*, pages 8÷11.

### Gear pump dimensions (continued)

### SNP3NN – 02FA, 02DA and 02BA

This drawing shows the standard porting for 02FA, 02DA and 02BA.

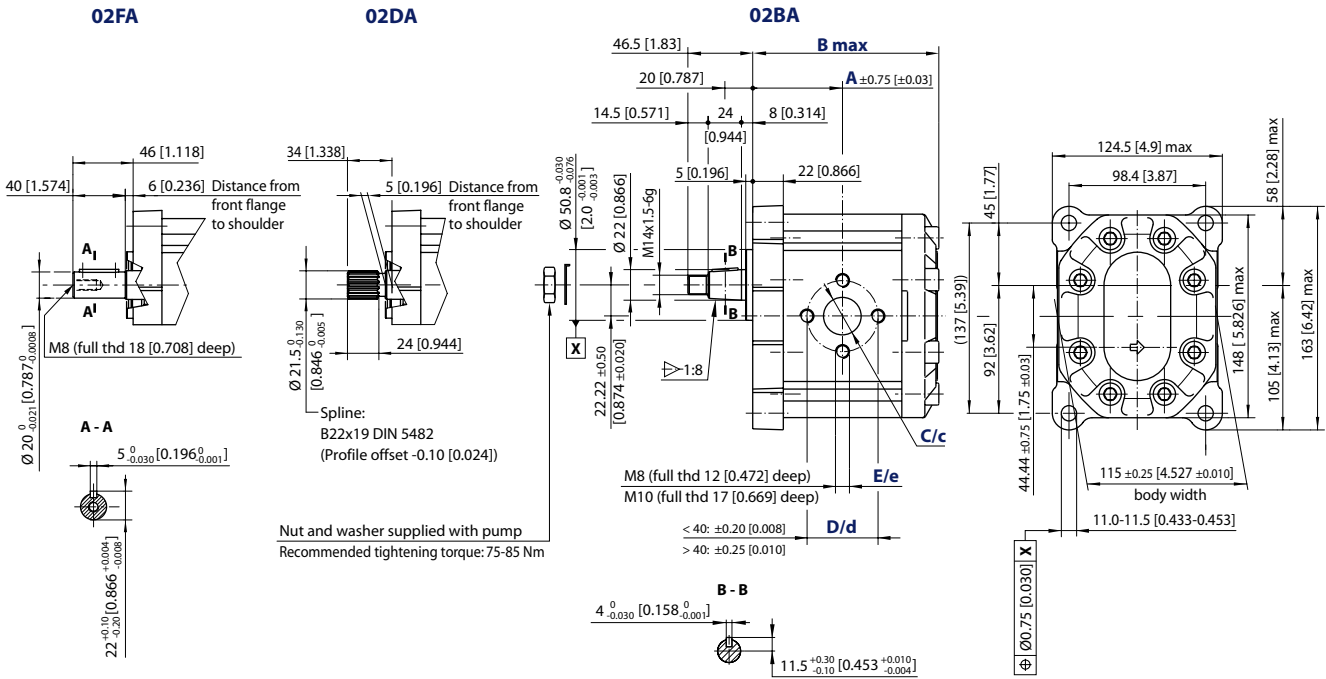

### SNP3NN – 02FA, 02DA and 02BA dimensions

Frame size		022	026	033	038	044	048	055	063	075	090
Dimension	A	63 [2.480]	64.5 [2.539]	67 [2.637]	68.8 [2.708]	71 [2.795]	72.5 [2.854]	75 [2.952]	78 [3.07]	82 [3.228]	87 [3.425]
	B	132.5 [5.216]	135.5 [5.334]	140.5 [5.531]	144 [5.669]	148.5 [5.846]	151.5 [5.964]	156.5 [6.161]	162.5 [6.397]	170.5 [6.712]	180.5 [7.106]
Inlet	C	20 [0.787]			27 [1.063]			36 [1.417]			
	D	40 [1.575]			51 [2.007]			62 [2.441]			
	E	M8			M10						
Outlet	c	20 [0.787]				27 [1.063]					
	d	40 [1.575]				51 [2.001]					
	e	M8				M10					

### Model code examples and maximum shaft torque

Flange/drive gear	Model code example	Maximum shaft torque
02FA	SNP3NN/044RN02FAP1CACANNNN/NNNNN	210 N•m [1858 lb•in]
02DA	SNP3NN/033RN02DAP1CAC7NNNN/NNNNN	290 N•m [2566 lb•in]
02BA	SNP3NN/026LN02BAP1C7C7NNNN/NNNNN	350 N•m [3097 lb•in]

For further details on ordering, see *Model Code*, pages 8÷11.

**Gear pump dimensions (continued)**

**SNP3NN – 03FB and 03BB**

This drawing shows the standard porting for 03FB and 03BB.

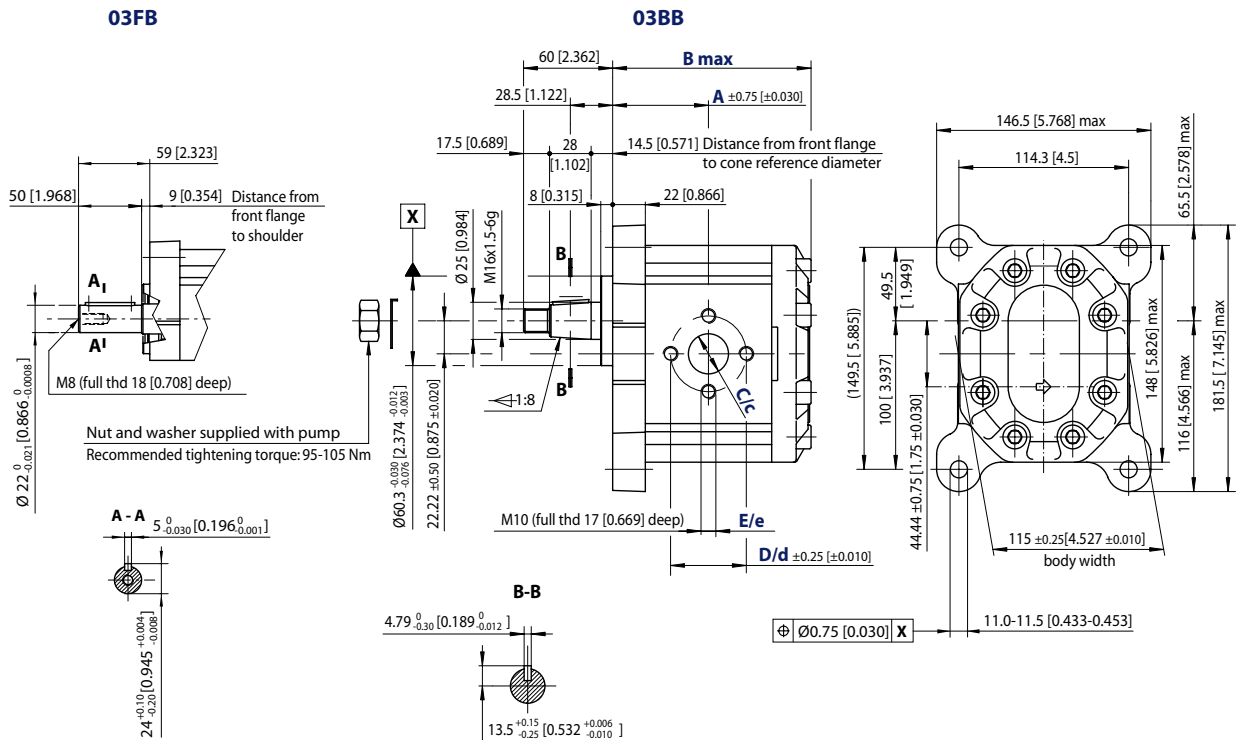

*SNP3NN – 03FB and 03BB dimensions*

Frame size	022	026	033	038	044	048	055	063	075	090	
Dimension	<b>A</b>	63 [2.480]	64.5 [2.539]	67 [2.637]	68.8 [2.708]	71 [2.795]	72.5 [2.854]	75 [2.952]	78 [3.07]	82 [3.228]	87 [3.425]
	<b>B</b>	132.5 [5.216]	135.5 [5.334]	140.5 [5.531]	144 [5.669]	148.5 [5.846]	151.5 [5.964]	156.5 [6.161]	162.5 [6.397]	170.5 [6.712]	180.5 [7.106]
Inlet	<b>C</b>	20 [0.787]			27 [1.063]			36 [1.417]			
	<b>D</b>	40 [1.575]			51 [2.007]			62 [2.441]			
	<b>E</b>	M8			M10						
Outlet	<b>c</b>	20 [0.787]				27 [1.063]					
	<b>d</b>	40 [1.575]				51 [2.001]					
	<b>e</b>	M8				M10					

*Model code examples and maximum shaft torque*

Flange/drive gear	Model code example	Maximum shaft torque
<b>03FB</b>	SNP3NN/044LN03FBP1CACANNNN/NNNNN	300 N•m [2655 lb•in]
<b>03BB</b>	SNP3NN/090RN03BBP1CDCANNNN/NNNNN	500 N•m [4425 lb•in]

For further details on ordering, see *Model Code*, pages 8÷11.





### Gear motor dimensions **SNM3NN – 01FA, 01DA and 01BA**

This drawing shows the standard porting for 01FA, 01DA and 01BA.

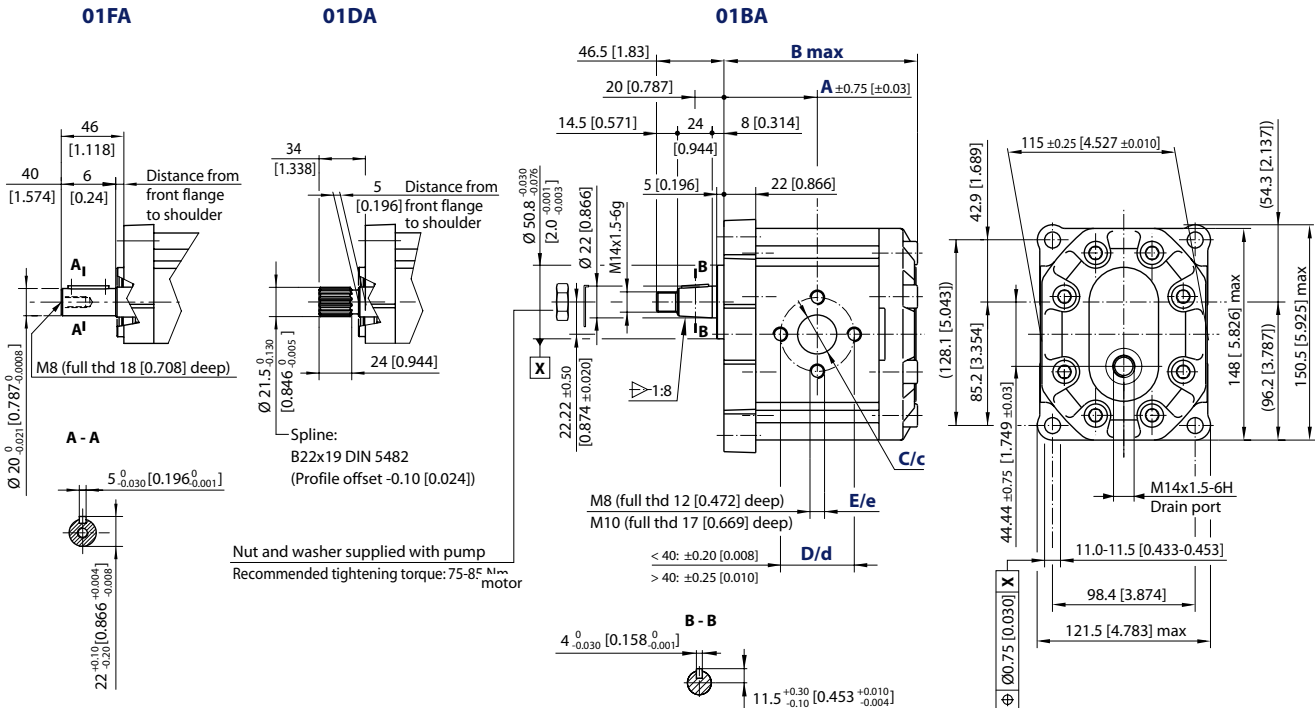

### SNM3NN – 01FA, 01DA and 01BA dimensions

Frame size	022	026	033	038	044	048	055	063	075	090	
Dimension	<b>A</b>	63 [2.48]	64.5 [2.539]	67 [2.637]	68.8 [2.708]	71 [2.795]	72.5 [2.854]	75 [2.952]	78 [3.07]	82 [3.228]	87 [3.425]
	<b>B</b>	132.5 [5.216]	135.5 [5.334]	140.5 [5.531]	144 [5.669]	148.5 [5.846]	151.5 [5.964]	156.5 [6.161]	162.5 [6.397]	170.5 [6.712]	180.5 [7.106]
Inlet/Outlet	<b>C/c</b>	20 [0.787]			27 [1.063]						
	<b>D/d</b>	40 [1.575]			51 [2.007]						
	<b>E/e</b>	M8			M10						

### Model code examples and maximum shaft torque

Flange/drive gear	Model code example	Maximum shaft torque
<b>01FA</b>	SNM3NN/075BN01FAM1CACANNNN/NNNNN	210 N•m [1858 lb•in]
<b>01DA</b>	SNM3NN/026BN01DAM1C7C7NNNN/NNNNN	290 N•m [2566 lb•in]
<b>01BA</b>	SNM3NN/044BN01BAM1CACANNNN/NNNNN	350 N•m [3097 lb•in]

For further details on ordering, see *Model Code*, pages 8÷11.

**Gear motor dimensions (continued)**

**SNM3NN – 02FA, 02DA and 02BA**

This drawing shows the standard porting for 02FA, 02DA and 02BA.

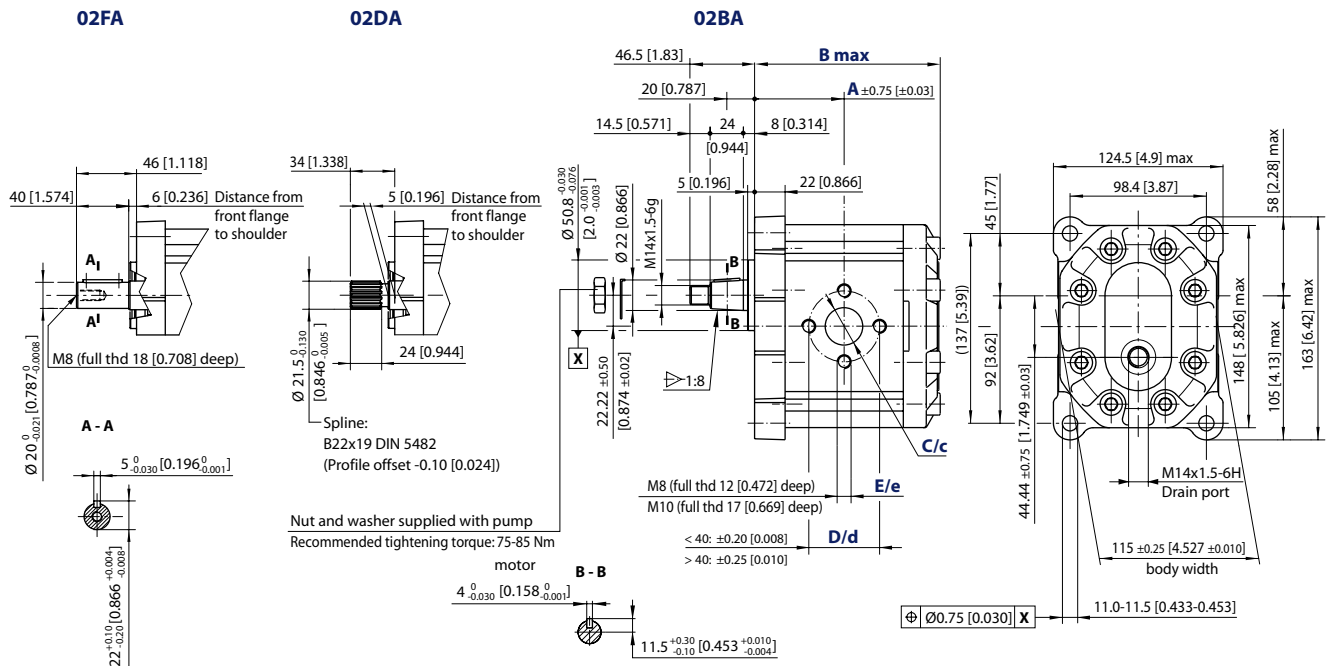

*SNM3NN – 02FA, 02DA and 02BA dimensions*

Frame size	022	026	033	038	044	048	055	063	075	090	
Dimension	A	63 [2.48]	64.5 [2.539]	67 [2.637]	68.8 [2.708]	71 [2.795]	72.5 [2.854]	75 [2.952]	78 [3.07]	82 [3.228]	87 [3.425]
	B	132.5 [5.216]	135.5 [5.334]	140.5 [5.531]	144 [5.669]	148.5 [5.846]	151.5 [5.964]	156.5 [6.161]	162.5 [6.397]	170.5 [6.712]	180.5 [7.106]
Inlet/Outlet	C/c	20 [0.787]		27 [1.063]							
	D/d	40 [1.575]		51 [2.007]							
	E/e	M8		M10							

*Model code examples and maximum shaft torque*

Flange/drive gear	Model code example	Maximum shaft torque
02FA	SNM3NN/044BN02FAM1CACANNNN/NNNNN	210 N•m [1858 lb•in]
02DA	SNM3NN/033BN02DAM1CACANNNN/NNNNN	290 N•m [2566 lb•in]
02BA	SNM3NN/026BN02BAM1C7C7NNNN/NNNNN	350 N•m [3097 lb•in]

For further details on ordering, see *Model Code*, pages 8÷11.





**Gear motor dimensions (continued)**

**SNM3NN – 06DD and 06AA**

This drawing shows the standard porting for 06DD AND 06AA.

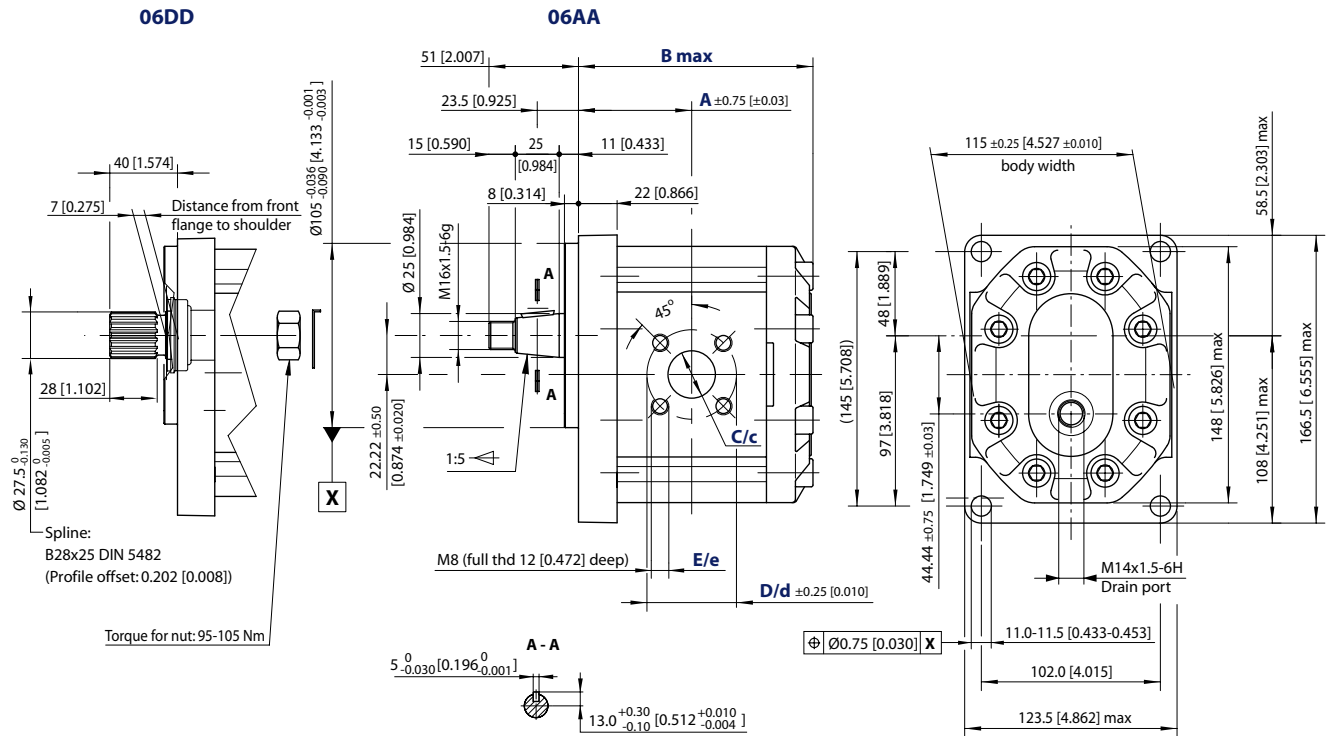

*SNM3NN – 06DD AND 06AA dimensions*

Frame size	022	026	033	038	044	048	055	063	075	090	
Dimension	A	63 [2.48]	64.5 [2.539]	67 [2.637]	68.8 [2.708]	71 [2.795]	72.5 [2.854]	75 [2.952]	78 [3.07]	82 [3.228]	87 [3.425]
	B	132.5 [5.216]	135.5 [5.334]	140.5 [5.531]	144 [5.669]	148.5 [5.846]	151.5 [5.964]	156.5 [6.161]	162.5 [6.397]	170.5 [6.712]	180.5 [7.106]
Inlet/Outlet	C/c	18 [0.709]			27 [1.063]			36 [1.417]			
	D/d	55 [2.165]									
	E/e	M8									

*Model code examples and maximum shaft torque*

Flange/drive gear	Model code example	Maximum shaft torque
06DD	SNM3NN/044BN06DDM1BBBBNNNN/NNNNN	300 N•m [2655 lb•in]
06AA	SNM3NN/022BN06AAM1BABANNNN/NNNNN	450 N•m [3982 lb•in]

For further details on ordering, see *Model Code*, pages 8÷11.

### Gear motor dimensions (continued)

### SNM3NN – 07BC, 07SA and 07GA

This drawing shows the standard porting for 07BC, 07SA and 07GA.

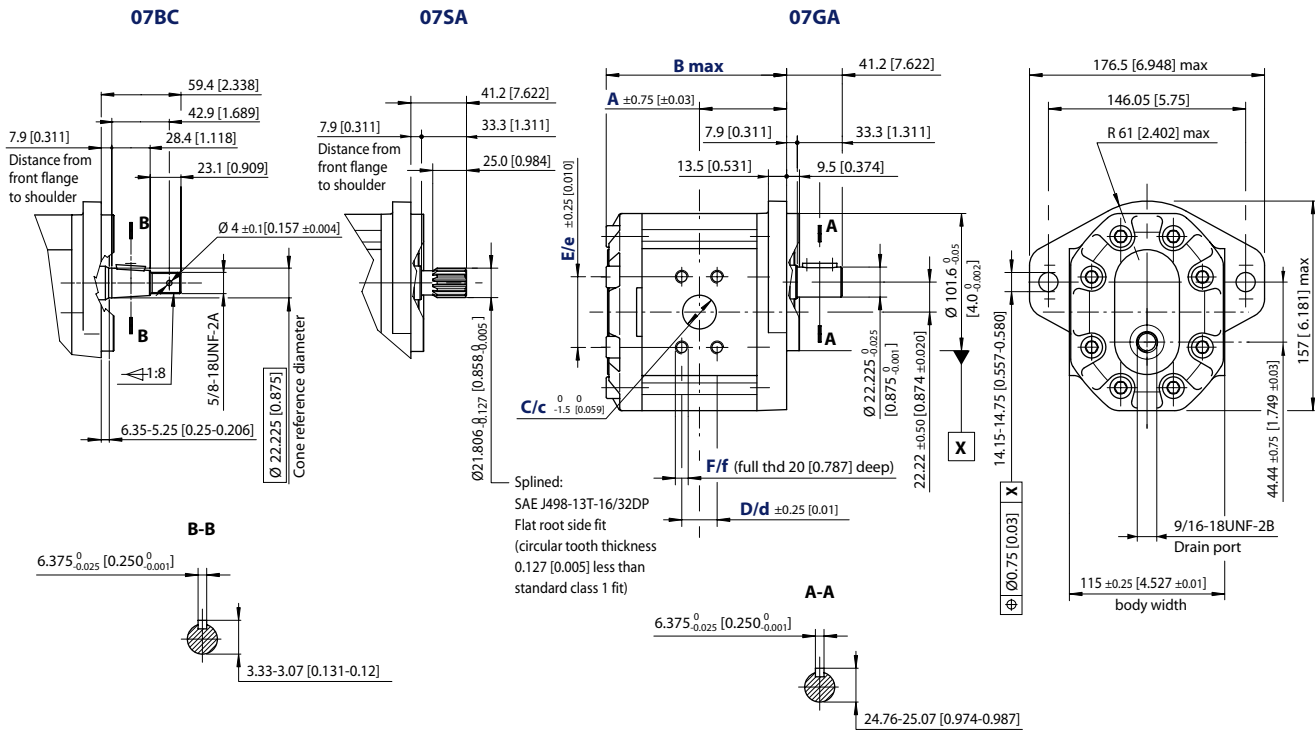

### SNM3NN – 07BC, 07SA and 07GA dimensions

Frame size	022	026	033	038	044	048	055	063	075	090	
Dimension	A	63 [2.48]	64.5 [2.539]	67 [2.637]	68.8 [2.708]	71 [2.795]	72.5 [2.854]	75 [2.952]	78 [3.07]	82 [3.228]	87 [3.425]
	B	132.5 [5.216]	135.5 [5.334]	140.5 [5.531]	144 [5.669]	148.5 [5.846]	151.5 [5.964]	156.5 [6.161]	162.5 [6.397]	170.5 [6.712]	180.5 [7.106]
Inlet/Outlet	C/c	25.4 [1]		31.8 [1.251]							
	D/d	26.19 [1.031]		30.18 [1.188]							
	E/e	52.37 [2.061]		58.72 [2.311]							
	F/f	3/8-16UNC-2B		7/16-14UNC-2B							

### Model code examples and maximum shaft torque

Flange/drive gear	Model code example	Maximum shaft torque
07BC	SNM3NN/026BN07BCM6A3A3NNNN/NNNNN	300 N•m [2655 lb•in]
07SA	SNM3NN/063BN07SAM6A4A4NNNN/NNNNN	270 N•m [2389 lb•in]
07GA	SNM3NN/090BN07GAM6A4A4NNNN/NNNNN	230 N•m [2035 lb•in]

For further details on ordering, see *Model Code*, pages 8÷11.

### Pump ports

### Available pump ports for Group 3

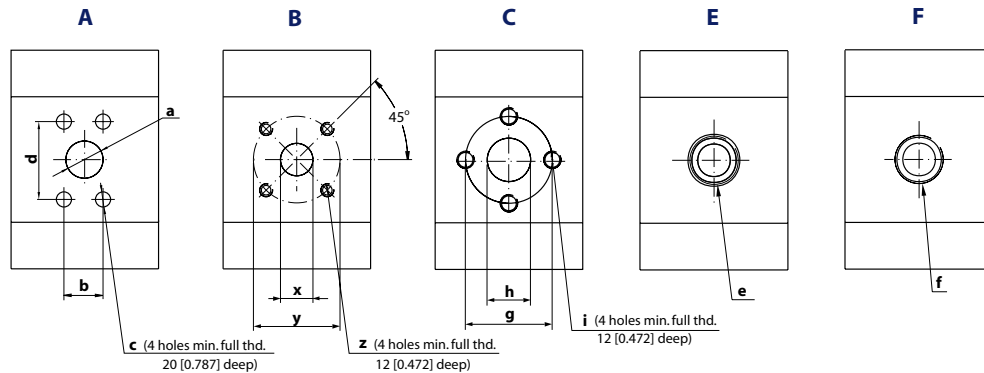

### Group 3 pump ports dimensions

Port type		A			B			C			E	F		
Main dimensions		a	b	d	c	x	y	z	g	h	i	e	f	
Frame size	022	Inlet	25.4 [1]	26.19 [1.031]	52.37 [2.062]	3/8-16UNC-2B	27 [1.063]	55 [2.165]	M8	40 [1.575]	20 [0.787]	M8	1 5/16-12UN-2B	3/4 Gas (BSPP)
		Outlet	18.5 [0.728]	22.23 [0.875]	47.63 [1.875]	3/8-16UNC-2B	18 [0.709]	55 [2.165]	M8	40 [1.575]	20 [0.787]	M8	1 1/16-12UN-2B	3/4 Gas (BSPP)
	026	Inlet	25.4 [1]	26.19 [1.031]	52.37 [2.062]	3/8-16UNC-2B	27 [1.063]	55 [2.165]	M8	40 [1.575]	20 [0.787]	M8	1 5/16-12UN-2B	3/4 Gas (BSPP)
		Outlet	18.5 [0.728]	22.23 [0.875]	47.63 [1.875]	3/8-16UNC-2B	18 [0.709]	55 [2.165]	M8	40 [1.575]	20 [0.787]	M8	1 1/16-12UN-2B	3/4 Gas (BSPP)
	033	Inlet	31.8 [1.252]	30.18 [1.188]	58.72 [2.312]	7/16-14UNC-2B	27 [1.063]	55 [2.165]	M8	51 [2.008]	27 [1.063]	M10	1 5/8-12UN-2B	1 Gas (BSPP)
		Outlet	25.4 [1]	26.19 [1.031]	52.37 [2.062]	3/8-16UNC-2B	18 [0.709]	55 [2.165]	M8	40 [1.575]	20 [0.787]	M8	1 5/16-12UN-2B	3/4 Gas (BSPP)
	038	Inlet	31.8 [1.252]	30.18 [1.188]	58.72 [2.312]	7/16-14UNC-2B	27 [1.063]	55 [2.165]	M8	51 [2.008]	27 [1.063]	M10	1 5/8-12UN-2B	1 Gas (BSPP)
		Outlet	25.4 [1]	26.19 [1.031]	52.37 [2.062]	3/8-16UNC-2B	18 [0.709]	55 [2.165]	M8	40 [1.575]	20 [0.787]	M8	1 5/16-12UN-2B	3/4 Gas (BSPP)
	044	Inlet	31.8 [1.252]	30.18 [1.188]	58.72 [2.312]	7/16-14UNC-2B	27 [1.063]	55 [2.165]	M8	51 [2.008]	27 [1.063]	M10	1 5/8-12UN-2B	1 Gas (BSPP)
		Outlet	25.4 [1]	26.19 [1.031]	52.37 [2.062]	3/8-16UNC-2B	18 [0.709]	55 [2.165]	M8	51 [2.008]	27 [1.063]	M10	1 5/16-12UN-2B	1 Gas (BSPP)
	048	Inlet	31.8 [1.252]	30.18 [1.188]	58.72 [2.312]	7/16-14UNC-2B	27 [1.063]	55 [2.165]	M8	51 [2.008]	27 [1.063]	M10	1 5/8-12UN-2B	1 Gas (BSPP)
		Outlet	25.4 [1]	26.19 [1.031]	52.37 [2.062]	3/8-16UNC-2B	18 [0.709]	55 [2.165]	M8	51 [2.008]	27 [1.063]	M10	1 5/16-12UN-2B	1 Gas (BSPP)
055	Inlet	37.5 [1.476]	35.71 [1.406]	69.85 [2.750]	1/2-13UNC-2B	27 [1.063]	55 [2.165]	M8	51 [2.008]	27 [1.063]	M10	1 7/8-12UN-2B	1 Gas (BSPP)	
	Outlet	31.8 [1.252]	30.18 [1.188]	58.72 [2.312]	7/16-14UNC-2B	18 [0.709]	55 [2.165]	M8	51 [2.008]	27 [1.063]	M10	1 5/8-12UN-2B	1 Gas (BSPP)	
063	Inlet	37.5 [1.476]	35.71 [1.406]	69.85 [2.750]	1/2-13UNC-2B	36 [1.417]	55 [2.165]	M8	62 [2.441]	36 [1.417]	M10	1 7/8-12UN-2B	1 1/4 Gas (BSPP)	
	Outlet	31.8 [1.252]	30.18 [1.188]	58.72 [2.312]	7/16-14UNC-2B	27 [1.063]	55 [2.165]	M8	51 [2.008]	27 [1.063]	M10	1 5/8-12UN-2B	1 Gas (BSPP)	
075	Inlet	37.5 [1.476]	35.71 [1.406]	69.85 [2.750]	1/2-13UNC-2B	36 [1.417]	55 [2.165]	M8	62 [2.441]	36 [1.417]	M10	1 7/8-12UN-2B	1 1/4 Gas (BSPP)	
	Outlet	31.8 [1.252]	30.18 [1.188]	58.72 [2.312]	7/16-14UNC-2B	27 [1.063]	55 [2.165]	M8	51 [2.008]	27 [1.063]	M10	1 5/8-12UN-2B	1 Gas (BSPP)	
090	Inlet	37.5 [1.476]	35.71 [1.406]	69.85 [2.750]	1/2-13UNC-2B	36 [1.417]	55 [2.165]	M8	62 [2.441]	36 [1.417]	M10	1 7/8-12UN-2B	1 1/4 Gas (BSPP)	
	Outlet	31.8 [1.252]	30.18 [1.188]	58.72 [2.312]	7/16-14UNC-2B	27 [1.063]	55 [2.165]	M8	51 [2.008]	27 [1.063]	M10	1 5/8-12UN-2B	1 Gas (BSPP)	

### Motor ports

Available motor ports for Group 3

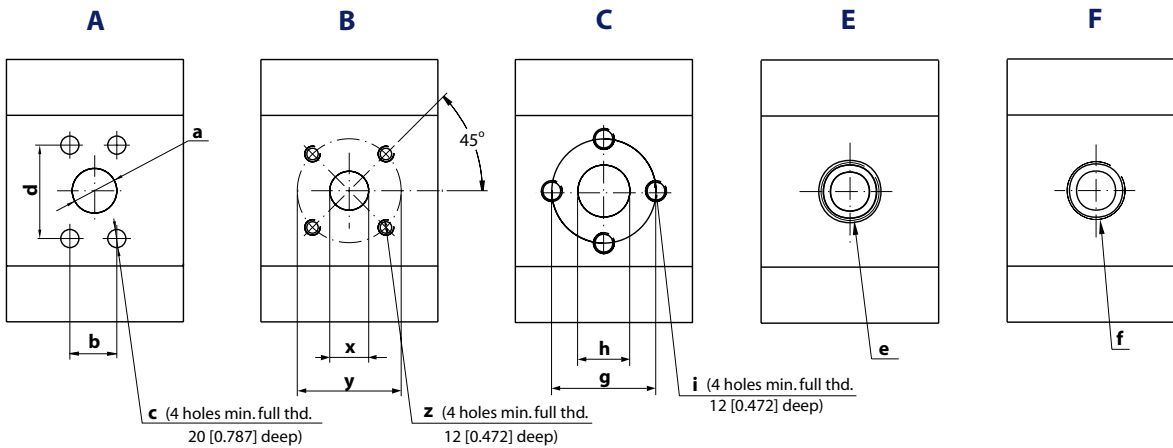

### Group 3 motor ports dimensions

Port type	A				B			C			E	F	
Main dimensions	a	b	d	c	x	y	z	g	h	i	e	f	
Frame size	<b>022</b> Inlet/Outlet	25.4 [1.0]	26.19 [1.031]	52.37 [2.061]	3/8-16UNC-2B	18 [0.709]	55 [2.165]	M8	40 [1.575]	20 [0.787]	M8	1 1/16-12UN-2B	3/4 Gas (BSPP)
	<b>026</b> Inlet/Outlet	25.4 [1.0]	26.19 [1.031]	52.37 [2.061]	3/8-16UNC-2B	18 [0.709]	55 [2.165]	M8	40 [1.575]	20 [0.787]	M8	1 1/16-12UN-2B	3/4 Gas (BSPP)
	<b>033</b> Inlet/Outlet	31.8 [1.251]	30.18 [1.188]	58.72 [2.311]	7/16-14UNC-2B	27 [1.063]	55 [2.165]	M8	51 [2.008]	27 [1.063]	M10	1 5/8-12UN-2B	1 Gas (BSPP)
	<b>038</b> Inlet/Outlet	31.8 [1.251]	30.18 [1.188]	58.72 [2.311]	7/16-14UNC-2B	27 [1.063]	55 [2.165]	M8	51 [2.008]	27 [1.063]	M10	1 5/8-12UN-2B	1 Gas (BSPP)
	<b>044</b> Inlet/Outlet	31.8 [1.251]	30.18 [1.188]	58.72 [2.311]	7/16-14UNC-2B	27 [1.063]	55 [2.165]	M8	51 [2.008]	27 [1.063]	M10	1 5/8-12UN-2B	1 Gas (BSPP)
	<b>048</b> Inlet/Outlet	31.8 [1.251]	30.18 [1.188]	58.72 [2.311]	7/16-14UNC-2B	27 [1.063]	55 [2.165]	M8	51 [2.008]	27 [1.063]	M10	1 5/8-12UN-2B	1 Gas (BSPP)
	<b>055</b> Inlet/Outlet	31.8 [1.251]	30.18 [1.188]	58.72 [2.311]	7/16-14UNC-2B	27 [1.063]	55 [2.165]	M8	51 [2.008]	27 [1.063]	M10	1 5/8-12UN-2B	1 Gas (BSPP)
	<b>063</b> Inlet/Outlet	31.8 [1.251]	30.18 [1.188]	58.72 [2.311]	7/16-14UNC-2B	36 [1.417]	55 [2.165]	M8	51 [2.008]	27 [1.063]	M10	1 5/8-12UN-2B	1 1/4 Gas (BSPP)
	<b>075</b> Inlet/Outlet	31.8 [1.251]	30.18 [1.188]	58.72 [2.311]	7/16-14UNC-2B	36 [1.417]	55 [2.165]	M8	51 [2.008]	27 [1.063]	M10	1 5/8-12UN-2B	1 1/4 Gas (BSPP)
<b>090</b> Inlet/Outlet	31.8 [1.251]	30.18 [1.188]	58.72 [2.311]	7/16-14UNC-2B	36 [1.417]	55 [2.165]	M8	51 [2.008]	27 [1.063]	M10	1 5/8-12UN-2B	1 1/4 Gas (BSPP)	
<b>Drain</b>	M14 x 1.5				7/16-18UNF-2B			M14 x 1.5			7/16-18UNF-2B		

#### Shaft and flange availability

#### Shaft and flange availability and torque capability

This table details the standard Group 3 shafts and flange combinations that are currently available with the maximum shaft torque limits. For further information, please see TurollaOCG publications *Group 3 Gear Pumps Technical Information*, **L1016456** and *Group 1, 2 and 3 Gear Motors, Technical Information*, **L1016082**.

#### Shaft and flange availability and torque capability

Shaft		Mounting flange code with maximum torque in Nm [lb·in]				
Description	Code	01	02	03	06	07
Taper 1:5	AA	–	–	–	300 [2655]	–
Taper 1:8	BA	350 [3097]	350 [3097]	–	–	–
Taper 1:8	BB	–	–	500 [4425]	–	–
Taper 1:8	BC	–	–	–	–	300 [2655]
Spline 13T DIN 5482-B22X19	DA	290 [2566]	290 [2566]	–	–	–
Spline 15T DIN 5482-B28X25	DD	–	–	–	450 [3982]	–
SAE spline 13T 16/32p	SA	–	–	–	–	270 [2389]
Parallel ø20 mm	FA	210 [1858]	210 [1858]	–	–	–
Parallel ø22.225 mm	FB	–	–	300 [2655]	–	–
Parallel ø22.225 mm	GA	–	–	–	–	230 [2035]

## General Aluminum Gear Pumps and Motors Technical Information Multi-Stage Pumps

### Overview

TuroliaOCG multi-stage pumps can be combined of group 1, 2, and 3. In addition to the standard range (presented in the following), first stage can be supplied with a splined, a tapered or a parallel shaft. Also versions with suction connection and other hydraulic connections and flange assembly or centralized threads are available.

The representatives of TuroliaOCG multi-stage pumps are shown below:  
*Tandem pump PTT conf. 06SM*

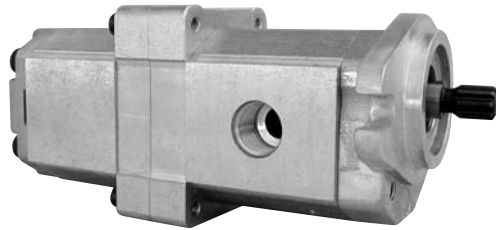

*Tandem pump PNT conf. 01BQ (cut-away)*

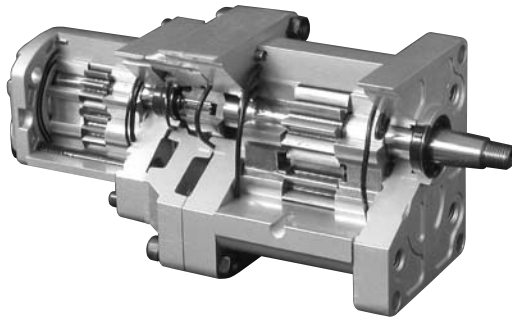

*Triple pump PFRN conf. 31BD*

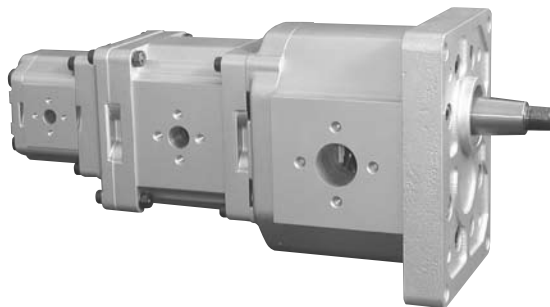

**Multi-stage pump model code** Example: PRRNN-022/022/...

**A B C D E F G \* \*\* H I J K L M N O P R S T U V W**  
 P R R N N - 0 2 2 / 0 2 2 / 0 1 7 / 4 , 0 L 0 0 7 S L P 3 B B B A N N B B B A N N N N / N N N N N N

**A** Product = Pump

**B** 1<sup>st</sup> stage group

**C** 2<sup>nd</sup> stage group

**D** 3<sup>rd</sup> stage group

**E** 4<sup>th</sup> stage group

Code	Stage group
T	Group 1 - series N
Y	Group 1 - series K
N	Group 2 - series N
L	Group 2 - series K
R	Group 3 - series N
F	Group 4 - series TA

**F** Displacement of the 1<sup>st</sup> stage pump

**G** Displacement of the 2<sup>nd</sup> stage pump

**\*** Displacement of the 3<sup>rd</sup> stage pump (optional)

**\*\*** Displacement of the 4<sup>th</sup> stage pump (optional)

**H** Direction of rotation

Code	Description
R	Right (clockwise)
L	Left (counterclockwise)

**I** Version

Code	Description
N	Standard (w/o interm.flange)
0	Interm. flange btw different group stages
1	Interm. flange all stages
2	SAE interm. flange btw different group stages
S	SAE interm. flange all stages

**J** Mounting flange and gear shaft –  
Group 1 as the first stage

Code	Description
01BT	European 4 bolt flange/Tapered shaft 1:8
01DM	European 4 bolt flange/DIN splined shaft 15T

**J** Mounting flange and gear shaft –  
Group 2 as the first stage

Code	Description
01BQ	European 4 bolt flange/Tapered shaft 1:8
02AG	German 4 bolt PTO flange/1:5 taper shaft
04AG	German 2 bolt PTO flange (Deutz)/1:5 taper shaft
05AG	German 2 bolt PTO flange (Deutz)/1:5 taper shaft
09BY	Perkins 4.236 timing case flange/1:8 taper shaft
06GE	SAE „A“ flange/15.875mm [0.625 in] parallel shaft
01DM	European 4-bolt flange/DIN splined shaft 9T
02DO	German 4-bolt PTO flange/DIN splined shaft 9T
04DO	German 2-bolt PTO flange (Deutz)/DIN splined shaft 9T
05DO	German 2-bolt PTO flange (Deutz)/DIN splined shaft 9T
06SM	SAE A flange/SAE splined shaft 9T
06SS	SAE A flange/SAE splined shaft 11T

**J** Mounting flange and gear shaft –  
Group 3 as the first stage

Code	Description
01BL	European 01 4-bolt flange/Tapered shaft 1:8
02BL	European 02 4-bolt flange/Tapered shaft 1:8
03BM	European 03 4-bolt flange/Tapered shaft 1:8
06AG	German 4-bolt flange/1:5 Tapered shaft
07GD	SAE B flange/Parallel shaft 22.225 mm [0.875 in]
01DL	European 01 4-bolt flange/DIN splined shaft 13T
06DO	German 4-bolt flange/SAE splined shaft 15T
07SL	SAE B flange/SAE splined shaft 13T

**J** Mounting flange and gear shaft –  
Group 4 as the first stage

Code	Description
31BD	European 4-bolt flange/Tapered shaft 1:8
02RD	SAE C 2-bolt flange/SAE splined shaft 14T

For further information about options of single units, see *Model Code*, pages 8 ÷ 11 of the catalogue.

**Multi-stage pump model code (continued)**

Example: PRRNN-022/022/...

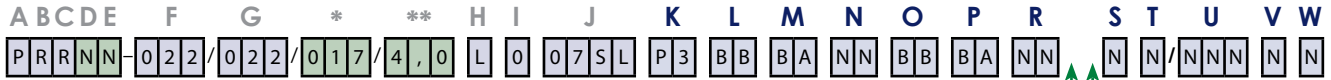

B 7 B 5 N N

*3<sup>rd</sup> stage group (optional)*  
B7 = Inlet  
B5 = Outlet  
NN = Ports Position

B 6 B 5 N N

*4<sup>th</sup> stage group (optional)*  
B6 = Inlet  
B5 = Outlet  
NN = Ports Position

**K** Rear cover

**L/M** Inlet/Outlet of the 1st stage pump

**N** Ports position of the 1st stage pump

**O/P** Inlet/Outlet of the 2nd stage pump

**R** Ports position of the 2nd stage pump

*Inlet/Outlet/Ports position of the 3<sup>rd</sup> stage pump*

*Inlet/Outlet/Ports position of the 4<sup>th</sup> stage pump*

**S** Seals

Code	Description
N	Buna seals

**T** Screws

Code	Description
N	Standard screws

**U** Set RV

Code	Description
NNN	No Valve
V**	Integr. RV valve

**V** Mark

Code	Description
N	Standard Mark

**W** Mark position

Code	Description
N	Standard position

For further information about options of single units, see *Model Code*, pages 8 ÷ 11 of the catalogue.



Multi-stage pump  
model code  
(continued)

Market codes for composition of multi-stage pumps

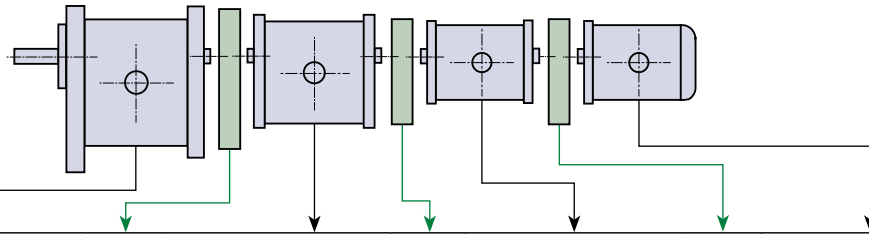

Family	Vers.	Front stage Flange + shaft	Kit type	Middle stage Flange + shaft	Kit type	Middle stage Flange + shaft	Kit type	Rear stage Flange + shaft
PTT	1	SNW1NN/.....01BT..	HU	-	-	-	-	SNP1NN/.....01DA..
PTT	N	SNW1NN/.....01BT..	HT	-	-	-	-	SNQ1NN/.....11DE
PNT	N	SNW2NN/.....01BQ..	HN	-	-	-	-	SNQ1NN/.....21DE
PNT	1	SNW2NN/.....01BQ..	CC	-	-	-	-	SNP1NN/.....01DA
PNN	N	SNW2NN/.....01BQ..	-	-	-	-	-	SNP2NN/.....03CA
PLN	N	SKW2NN/.....01BQ..	-	-	-	-	-	SNP2NN/.....03CA
PRT	N	SNW3NN/.....01BL..	HR	-	-	-	-	SNQ1NN/.....31DE
PRT	1	SNW3NN/.....01BL..	Q	-	-	-	-	SNP1NN/.....01DA..
PRN	1	SNW3NN/.....01BL..	H	-	-	-	-	SNP2NN/.....01DA..
PRR	N	SNW3NN/.....01BL..	G	-	-	-	-	SNQ3NN/.....11DB..
PFN	1	TAW4NN/.....31BD..	S	-	-	-	-	SNP2NN/.....01DA..
PFR	1	TAW4NN/.....31BD..	E	-	-	-	-	SNQ3NN/.....11DB..
PFF	N	TAW4NN/.....31BD..	F	-	-	-	-	TAQ4NN/.....31DB..
PTTT	N	SNW1NN/.....01BT..	HT	SNO1NN/.....11BP..	HT	-	-	SNQ1NN/.....11DE..
PTTT	1	SNW1NN/.....01BT..	HU	SNW1NN/.....01DM..	HU	-	-	SNP1NN/.....01DA..
PNTT	N	SNW2NN/.....01BQ..	HN	SNO1NN/.....21DP..	HT	-	-	SNQ1NN/.....11DE..
PNTT	1	SNW2NN/.....01BQ..	CC	SNW1NN/.....01DM..	HU	-	-	SNP1NN/.....01DA..
PNNT	0	SNW2NN/.....01BQ..	-	SNO2NN/.....03CH..	CC	-	-	SNP1NN/.....01DA..
PNNN	N	SNW2NN/.....01BQ..	-	SNO2NN/.....03CH..	-	-	-	SNP2NN/.....01CA..
PRNT	1	SNW3NN/.....01BL..	H	SNW2NN/.....01DM..	CC	-	-	SNP1NN/.....01DA..
PRNN	0	SNW3NN/.....01BL..	H	SNW2NN/.....01DM..	-	-	-	SNP2NN/.....03CA..
PRRT	0	SNW3NN/.....01BL..	G	SNO3NN/.....11DM..	Q	-	-	SNP1NN/.....01DA..
PRRN	0	SNW3NN/.....01BL..	G	SNO3NN/.....11DM..	H	-	-	SNP2NN/.....03CA..
PRRR	N	SNW3NN/.....01BL..	G	SNO3NN/.....11DM..	G	-	-	SNQ3NN/.....11DB..
PFNN	0	TAW4NN/.....31BD..	S	SNW2NN/.....01DM..	-	-	-	SNP2NN/.....03CA..
PFRN	1	TAW4NN/.....31BD..	E	SNO3NN/.....11DM..	H	-	-	SNP2NN/.....01DA..
PFRR	0	TAW4NN/.....31BD..	E	SNO3NN/.....11DM..	G	-	-	SNQ3NN/.....11DB..
PFFR	0	TAW4NN/.....31BD..	F	TAO4NN/.....31DE..	E	-	-	SNQ3NN/.....11DB..
PNNNT	0	SNW2NN/.....01BQ..	-	SNO2NN/.....03CH..	-	SNO2NN/.....03CH..	V	SNP1NN/.....01DA..
PNNNN	N	SNW2NN/.....01BQ..	-	SNO2NN/.....03CH..	-	SNO2NN/.....03CH..	-	SNP2NN/.....03CA..
PRNTT	1	SNW3NN/.....01BL..	H	SNW2NN/.....01DM..	CC	SNW1NN/.....01DM..	HU	SNP1NN/.....01DA..
PRNNN	0	SNW3NN/.....01BL..	H	SNW2NN/.....01DM..	-	SNO2NN/.....03CH..	-	SNP2NN/.....03CA..
PRRNN	0	SNW3NN/.....01BL..	G	SNO3NN/.....11DM..	H	SNW2NN/.....01DM..	-	SNP2NN/.....03CA..
PRRRN	0	SNW3NN/.....01BL..	G	SNO3NN/.....11DM..	G	SNO3NN/.....11DM..	HU	SNP2NN/.....03CA..
PRRRR	N	SNW3NN/.....01BL..	G	SNO3NN/.....11DM..	G	SNO3NN/.....11DM..	G	SNQ3NN/.....11DB..
PFRNN	0	TAW4NN/.....31BD..	E	SNO3NN/.....11DM..	H	SNW2NN/.....01DM..	-	SNP2NN/.....03CA..
PFRRN	0	TAW4NN/.....31BD..	E	SNO3NN/.....11DM..	G	SNO3NN/.....11DM..	HU	SNP2NN/.....03CA..
PFFRR	0	TAW4NN/.....31BD..	E	SNO3NN/.....11DM..	G	SNO3NN/.....11DM..	G	SNQ3NN/.....11DB..

To assemble tandem pumps, consider first and rear stage; for triple pumps consider first, middle and rear stage; for quadruple pumps consider all stages. Above table shows the 1:8 taper shaft in combination with 01 flange standard design only, corresponding to 1:8 taper shaft of single pump. For different configurations of shaft and front flange see the pages regarding single pumps.

# General Aluminum Gear Pumps and Motors

## Technical Information

### Multi-Stage Pumps

Multi-stage pumps with European standard front flange (01)

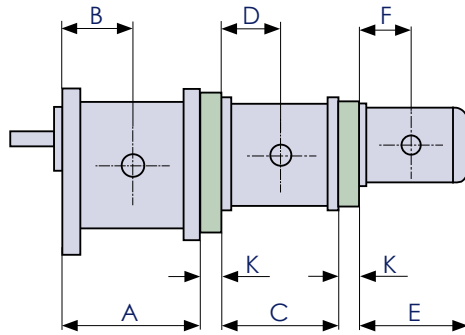

Coupling kit width – K mm [in]	
SNP1NN + SNP1NN	0
SNP2NN + SNP1NN	0
SNP2NN + SNP2NN	0
SNP3NN + SNP1NN	0
SNP3NN + SNP2NN	25 [0.984]
SNP3NN + SNP3NN	0
TAP4NN + SNP1NN	23.5 [0.925]
TAP4NN + SNP2NN	25 [0.984]
TAP4NN + SNP3NN	0
TAP4NN + TAP4NN	0

All groups – dimensions (mm) [in]

Product type, size		A	B	C	D	E	F	
Group 1	SNP1NN SKP1NN	1,2	75.75 [2.982]	37.75 [1.486]	76.00 [2.992]	38.00 [1.496]	79.75 [3.140]	38.00 [1.496]
		1,7	77.25 [3.041]	38.50 [1.515]	77.50 [3.051]	38.75 [1.525]	81.25 [3.199]	38.75 [1.525]
		2,2	79.25 [3.120]	39.50 [1.555]	79.50 [3.130]	39.75 [1.565]	83.25 [3.278]	39.75 [1.565]
		2,6	81.25 [3.199]	40.50 [1.594]	81.50 [3.208]	40.75 [1.604]	85.25 [3.356]	40.75 [1.604]
		3,2	83.25 [3.278]	41.50 [1.634]	83.50 [3.287]	41.75 [1.644]	87.25 [3.435]	41.75 [1.644]
		3,8	85.25 [3.356]	42.50 [1.673]	85.50 [3.366]	42.75 [1.683]	89.25 [3.514]	42.75 [1.683]
		4,3	87.25 [3.435]	43.50 [1.712]	87.50 [3.445]	43.75 [1.722]	91.25 [3.592]	43.75 [1.722]
		6,0	93.75 [3.691]	46.75 [1.840]	94.00 [3.701]	47.00 [1.850]	97.75 [3.848]	47.00 [1.850]
		7,8	100.25 [3.947]	50.0 [1.968]	100.5 [3.956]	50.25 [1.978]	104.25 [4.104]	50.25 [1.978]
		10	109.25 [4.301]	54.50 [2.145]	109.5 [4.311]	54.75 [2.155]	113.25 [4.458]	54.75 [2.155]
12	117.25 [4.616]	58.50 [2.303]	117.5 [4.626]	58.75 [2.313]	121.25 [4.773]	58.75 [2.313]		
Group 2	SNP2NN SKP2NN	4,0	87.50 [3.445]	43.3 [1.705]	87.50 [3.445]	43.3 [1.705]	93.0 [3.661]	43.3 [1.705]
		6,0	91.0 [3.582]	45.0 [1.771]	91.00 [3.582]	45.0 [1.771]	96.5 [3.799]	45.0 [1.771]
		8,0	95.0 [3.740]	45.0 [1.771]	95.00 [3.740]	45.0 [1.771]	100.5 [3.956]	45.0 [1.771]
		11	99.0 [3.897]	49.0 [1.929]	99.00 [3.897]	49.0 [1.929]	104.5 [4.114]	49.0 [1.929]
		14	105.0 [4.134]	52.0 [2.047]	105.0 [4.134]	52.0 [2.047]	110.5 [4.350]	52.0 [2.047]
		17	109.0 [4.291]	52.0 [2.047]	109.0 [4.291]	52.0 [2.047]	114.5 [4.508]	52.0 [2.047]
		19	113.0 [4.449]	56.0 [2.205]	113.0 [4.449]	56.0 [2.205]	118.5 [4.665]	56.0 [2.205]
		22	119.0 [4.685]	59.0 [2.323]	119.0 [4.685]	59.0 [2.323]	124.5 [4.902]	59.0 [2.323]
25	123.0 [4.843]	59.0 [2.323]	123.0 [4.843]	59.0 [2.323]	128.5 [5.059]	59.0 [2.323]		
Group 3	SNP3NN	22	126.0 [4.960]	63.0 [2.480]	126.0 [4.960]	63.0 [2.480]	132.5 [5.216]	63.0 [2.480]
		26	129.0 [5.078]	64.5 [2.539]	129.0 [5.078]	64.5 [2.539]	135.5 [5.334]	64.5 [2.539]
		33	134.0 [5.275]	67.0 [2.637]	134.0 [5.275]	67.0 [2.637]	140.5 [5.531]	67.0 [2.637]
		38	137.5 [5.413]	68.8 [2.708]	137.5 [5.413]	68.8 [2.708]	144.0 [5.669]	68.8 [2.708]
		44	142.0 [5.590]	71.0 [2.795]	142.0 [5.590]	71.0 [2.795]	148.5 [5.846]	71.0 [2.795]
		48	145.0 [5.708]	72.5 [2.854]	145.0 [5.708]	72.5 [2.854]	151.5 [5.964]	72.5 [2.854]
		55	150.0 [5.905]	75.0 [2.952]	150.0 [5.905]	75.0 [2.952]	156.5 [6.161]	75.0 [2.952]
		63	156.0 [6.141]	78.0 [3.071]	156.0 [6.141]	78.0 [3.071]	162.5 [6.397]	78.0 [3.071]
		75	164.0 [6.456]	82.0 [3.228]	164.0 [6.456]	82.0 [3.228]	170.5 [6.712]	82.0 [3.228]
		90	174.0 [6.850]	87.0 [3.425]	174.0 [6.850]	87.0 [3.425]	180.5 [7.106]	87.0 [3.425]
Group 4	TAP4NN	60	176.0 [6.929]	88.0 [3.464]	176.0 [6.929]	88.0 [3.464]	174.5 [6.870]	88.0 [3.464]
		85	186.0 [7.323]	93.0 [3.661]	186.0 [7.323]	93.0 [3.661]	184.5 [7.264]	93.0 [3.661]
		106	194.0 [7.637]	97.0 [3.819]	194.0 [7.637]	97.0 [3.819]	192.5 [7.578]	97.0 [3.819]
		130	203.0 [7.992]	101.5 [3.996]	203.0 [7.992]	101.5 [3.996]	201.5 [7.933]	101.5 [3.996]
		148	210.0 [8.267]	105.0 [4.134]	210.0 [8.267]	105.0 [4.134]	208.5 [8.208]	105.0 [4.134]
		180	222.0 [8.740]	111.0 [4.370]	222.0 [8.740]	111.0 [4.370]	220.5 [8.681]	111.0 [4.370]
200	230.0 [9.055]	115.0 [4.527]	230.0 [9.055]	115.0 [4.527]	228.5 [8.996]	115.0 [4.527]		

**Multi-stage pumps with  
European standard  
front flange (01)  
(continued)**

*Examples of overall length calculation:*

**2-stage pump: SNP3NN/044 + SNP1NN/3,2**

$$A = 142 \text{ mm}$$

$$K = 0$$

$$E = 87.25 \text{ mm}$$

$$L_{\text{tot}} = 142 + 0 + 87.25 = 229.25 \text{ mm}$$

**4-stage pump: SNP3NN/055 + SNP2NN/017 + SNP2NN/8,0 + SNP1NN/2,2**

$$A = 150 \text{ mm}$$

$$K = 25 \text{ mm (1° kit – 1<sup>st</sup> kit)}$$

$$C = 109 \text{ mm (2<sup>nd</sup> stage)}$$

$$K = 0 \text{ mm (2° kit – 2<sup>nd</sup> kit)}$$

$$C = 95 \text{ mm (3<sup>rd</sup> stage)}$$

$$K = 0 \text{ mm (3° kit – 3<sup>rd</sup> kit)}$$

$$E = 83.25 \text{ mm (4<sup>th</sup> stage)}$$

$$L_{\text{tot}} = 150 + 25 + 109 + 0 + 95 + 0 + 83.25 = 413.25 \text{ mm}$$

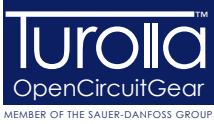

## Our Products

Aluminum Gear Pumps

Aluminum Gear Motors

Cast Iron Gear Pumps

Cast Iron Gear Motors

Fan Drive Gear Motors Aluminum

Fan Drive Gear Motors Cast Iron

## Turolla OpenCircuitGear™

TurollaOCG, with more than 60 years of experience in designing and manufacturing gear pumps, gear motors and fan drive motors of superior quality, is the ideal partner ensuring robustness and reliability to your work functions.

We are fast and responsive - the first to specify a customer product, the most experienced in providing technical knowledge and support for fan drive solutions.

We offer a lean value chain to our partners and customers and the shortest lead time in the market.

TurollaOCG is member of the Sauer-Danfoss Group.

### Local address:

#### **TurollaOCG**

Via Villanova 28  
40050 Villanova di Castenaso  
Bologna, Italy  
Phone: +39 051 6054411  
Fax: +39 051 6053033

#### **TurollaOCG**

Kukučínova 2148-84  
01701 Považská Bystrica, Slovakia  
Phone: +421 424 301 544  
Fax: +421 424 301 626

#### **TurollaOCG**

2800 East 13th Street  
Ames, IA 50010  
USA  
Phone: +1 515 239 6000  
Fax: +1 515 239 6618